

**WELCOME**

**@ CAMPING**



**HIGH PEAK**

**Collection 2024**



**OUR PASSION**



# Camping lieben und leben. So wie es gefällt.

**Camping as you like it.  
Love it and live it.**

Unsere Leidenschaft. | Our passion.

High Peak ist und bleibt die Marke für Camper. Mit größter Leidenschaft arbeiten wir von jeher daran, besser als jeder andere zu verstehen, was Camper brauchen und was sie begeistert.

High Peak is and remains the brand for campers. We have always worked with great passion to understand better than anyone else what campers need, and what inspires them.





## 39 Jahre Erfahrung. | 39 years of experience.

Von Anfang an, seit der Gründung von High Peak im Jahre 1984, war es uns wichtig, all die Erfahrungen und Erlebnisse aus den vielen Reisen ständig in die Entwicklung von Camping-Produkten einfließen zu lassen. Die Veränderungen in den Beschaffungsmärkten erlebten und gestalteten wir mit. So wurden wir zum Wegbegleiter für alle, die Camping leben und für die es immer wieder zum Erlebnis wird.

From the very beginning, since the establishment of High Peak in the year 1984, it was important for us to constantly put all the experiences and impressions from many journeys into the development of camping products. We have witnessed and helped to shape the changes in the procurement markets. In this way, we have become a companion for everyone who loves camping and for whom it is always an experience.





OUR COLLECTION



# Alles, was dazugehört.

## All you need.

High Peak ist der führende Campingausrüster mit Fokus auf die elementaren Funktionen, Design und das beste Preis-Leistungsverhältnis. Mit klaren, verständlichen Produktlinien für die einfache Auswahl. Alle Produkte unterliegen den gesetzlichen Vorgaben, Normen, sowie der europäischen Chemikalienverordnung REACH. Alle unsere Produktionsstätten werden überwacht und sind BSCI zertifiziert. Nachhaltigkeit ist für uns oberstes Gebot.

High Peak is the leading provider of camping equipment with its focus on elementary functions, design and excellent value for money. With clear, understandable product lines for simple selection. All products fulfil the legal requirements, standards and the European chemicals regulation REACH. All our production facilities are monitored and are BSCI certified. Sustainability is our highest priority.



## Zelte. | Tents.

Unser Materialanspruch ist die Zelt Norm DIN EN ISO 5912 und besser. Alle Zelte sind nahtversiegelt und mit einer hochwertigen PU-Beschichtung von mindestens 1500 bis zu 4000 mm ausgerüstet. Sie sind mit praxistauglichen Ventilationssystemen für Sicherheit und Komfort ausgestattet. Einfacher Aufbau durch farbige Gestänge-Markierungen und Aufbauvideos. Klare Produktlinien für Camping in allen Variationen.

Our material demands are in accordance with DIN EN ISO 5912 and even better. All tents are equipped with fully tape-sealed seams and a high-quality PU coating of at least 1500 up to 4000 mm. They are fitted with practical ventilation systems to ensure safety as well as highest comfort. Simple assembly with colored frame markings and assembly videos. Clear product lines for camping in all variations.



## Schlafsäcke. | Sleeping bags.

Für alle High Peak Schlafsäcke wird der Wärmedurchgangswiderstand in einer zertifizierten Klimakammer nach DIN EN ISO 23537-1:2016 getestet und der Temperaturwert ermittelt. Dura Loft® Hightech-Faserfüllungen werden in verschiedenen Zusammensetzungen für unterschiedliche Einsätze von uns entwickelt.

Dura Loft® wird ausschließlich in HIGH PEAK Schlafsäcken verarbeitet.

All High Peak sleeping bags are tested for thermal resistance in a certified climate chamber in accordance with DIN EN ISO 23537-1:2016.

Dura Loft® hightech fiber fillings are developed by us in various composition for individual conditions and exclusive for HIGH PEAK.



## Liegematten. | Mats.

Unsere selbstaufblasbaren Liegematten in verschiedenen Stärken und Übergrößen. Die von uns entwickelten High Peak Leichtgewicht-Luftmatratzen mit integrierter Pumpe bieten hohen Schlafkomfort und sind klein verpackt, bei bester Preisleistung.

Our self-inflating mats in various thickness and oversizes. High Peak lightweight air mattresses with integrated pumps offer comfort in a compact packaging and best value for money.

## Luftbetten. | Air beds.

Die von uns designten und entwickelten Luftbetten haben eine hautsympathische Oberfläche aus organischer Viskose für höchsten Schlafkomfort. Alle Luftbetten werden mit unseren neu entwickelten Anti-Rutsch-Pads (Geschmacksmuster) ausgerüstet. Mit der integrierten Pumpe ist das Luftbett minutenschnell aufgeblasen.

Our in-house designed and developed air beds have a skin-friendly surface made of organic rayon and horizontal air chambers offer the very highest degree of sleeping comfort. All air beds are provided with our newly developed anti-slip pads (design patent). The air bed is inflated within a matter of just a few minutes with the integrated pump.

A man with a beard and a ponytail is sitting on the ground next to a campfire at night. He is smiling and looking towards the fire. A tent is visible behind him. The scene is illuminated by the warm glow of the campfire and the cool blue light of the night sky.

# Für jeden das Richtige.

## The right equipment for everybody.

## Family

Wenn das Zuhause unterwegs ist.  
When home is on the road.

**Komfort-Camping:** Beim Camping-Urlaub mit Familie müssen Funktionalität und Komfort Hand in Hand gehen. Mit so wenig wie möglich muss so viel wie nötig gelingen. Kein Problem, wenn sich Spezialisten wie wir dazu ständig Gedanken machen. Gut, dass dann alles aufeinander abgestimmt ist. So macht 24 Stunden frische Luft auch allen richtig Spaß.

**Comfortable camping:** on a camping holiday with the family, functionality and comfort have to go hand in hand. The aim is to achieve as much as necessary with as little as possible. That's no problem when specialists like us are constantly on the job. Good that everything is so coordinated. So that 24 hours of fresh air can also be fun for everyone.

Faszination Camping hat viele Gesichter. Was alle vereint, ist das Erlebnis in der Gemeinschaft. Wichtig, ob mit der Familie, unterwegs mit Freunden oder beim Festival: Die Ausrüstung muss passen!

The "fascination of camping" has many faces. What unites them all is the experience of companionship. The important thing is though, whether you're with family, travelling with friends, or at a festival: the equipment has to be right!

# Friends

Die Freizeit mit Freunden verbringen.  
Spend your free time with friends.

**Aktives Camping:** Leicht und klein und gut verpackt soll alles sein, wenn Freunde zu gemeinsamen Abenteuern aufbrechen. Ob zu Land oder zu Wasser. Grillen, Fische fangen, ein Glas Sommerwein, was gibt es schöneres?

**Active camping:** everything needs to be lightweight, compact and well stowed when friends set off on adventures together. Whether on land or on water. Barbecues, catching fish, a glass of summer wine, what could be better?



# Events

Man trifft sich, man zelebriert und man feiert.  
You meet, you party.

**Robust, schnell und funktional:**

Mehr und mehr Festivals, Sportevents, Kirchentage und mehr laden ein. Großveranstaltungen werden zu Gemeinschaftserlebnissen. Da ist Mobilität und Schnelligkeit angesagt. Camping aufs funktionalste und einfachste. Ein echtes „Must have“: Das Wurfzelt. Zeltaufbau ade. Nur feiern.

**Robust, quick and functional**

is the motto when it comes to festivals, sport events, church conventions etc. Big events become community experiences. Here, mobility and speed are called for. Camping at its most functional and simplest. A real “must have”: the pop-up tent. No more pitching camp. Let the party begin.



# Camping Serie

## Camping series



### Die Camping Serie erfüllt folgende Kriterien:

Der Zeltstoff ist mit einer Fluorcarbon (PFC)-freien wasserabstoßenden Imprägnierung (DWR) an der Zelthaut-Außenseite ausgerüstet.

PFC steht für per- und polyfluorierte Chemikalien. PFC's haben wasser-öl-schmutz-abweisende Eigenschaften und werden häufig für Oberstoffe verwendet. Viele PFC's sind persistent, das heißt sie bauen sich nicht selbständig ab, sondern müssen unter extrem hohen Temperaturen verbrannt werden. Über Wasserwege, Luft und Nahrung verbreiten sich die Spuren auf der ganzen Welt.

Fluorcarbonfreie DWR Ausrüstungen sind häufig nicht so haltbar wie die herkömmlichen PFC-haltigen DWR Ausrüstungen. Deshalb ist ein Nach-Imprägnieren von Zeit zu Zeit notwendig. Bitte verwenden Sie ein fluorcarbonfreies Imprägniermittel.

### The Camping Series meets the following criteria:

The tent fabric is equipped with a fluorocarbon (PFC)-free water-repellent impregnation (DWR) on the outside of the fly sheet.

PFC stands for per- and polyfluorinated chemicals. PFCs have water-oil dirt-repellent properties and are often used for shell fabrics. Many PFCs are persistent, meaning they do not self-degrade but have to be burned at extremely high temperatures. Via water, air and nutrition the tracks are spreading around the world.

Fluorocarbon-free DWR finishes are often not as durable as conventional PFC-containing DWR finishes. Therefore, a re-impregnation is necessary from time to time. Please use a fluorocarbon-free impregnation.



Abgedunkeltes Innenzelt |  
Darkened inner tent



Vario Vent Control Eingang  
mit Gazefenster |  
Vario Vent Control entry  
with mesh window

Advanced Low Vent  
Belüftung mit Abdeckklappe |  
Advanced Low Vent  
ventilation with cover



INNOVATIONS



Advanced Low Vent System



Unsere Produktentwickler sind Ventilations-Fanatiker und entwickelten die neue Bodenbelüftung **ADVANCED LOW VENT SYSTEM**.

Eine funktionstüchtige Bodenbelüftung ist bei jeder Wetterlage von zentraler Bedeutung.

Our product developers are ventilation fanatics and developed the new ground level ventilation **ADVANCED LOW VENT SYSTEM**. Functional ground level ventilation for all climate conditions is of central significance.

Das **ADVANCED LOW VENT SYSTEM** ist eine sehr effektive Bodenventilation und zirkuliert die Luft im Bodenbereich an zwei Seiten auch bei schlechtem Wetter. Der extra große Abstand zwischen Außenzelt und Innenzelt reduziert Kondensation. Das **ADVANCED LOW VENT SYSTEM** wird mittels Öffnen der Gaze-Abdeckklappe bequem von der Innenseite aktiviert. Die Abdeckung wird in einer Tasche verstaut und muss nicht aufgerollt werden. Pfiffig ist die Bedienung der **ADVANCED LOW VENT** vom Innenzelt mittels Reißverschluss. Das Ventilationssystem ist bequem von Ihrem kuscheligen High Peak Schlafsack aus zu regulieren.

The **ADVANCED LOW VENT SYSTEM** is a highly effective ground level ventilation circulating air throughout the floor area on two sides. The extra space between outer tent and inner tent minimizes condensation. **ADVANCED LOW VENT SYSTEM** can be activated by opening the mesh cover from inside and store the cover easy in the cover garage. Cool idea to handle the **ADVANCED LOW VENT SYSTEM** from the inner tent by zip-opening. The ventilation system can comfortably be adjusted from your cozy High Peak sleeping bag.



Funktionale Zelte mit  
CLIMATE PROTECTION 80  
Ausstattung.

Klare Linien und aus-  
druckstarkes Design mit  
frischen Farb-Akzenten.

Functional tents equipped with  
CLIMATE PROTECTION 80.

Clean lines and expressive  
design with fresh  
color accents.



Qualität, die nie still steht.  
Quality that never stands still.



Unser Ziel ist es die Qualität ständig zu optimieren. Bei allen High Peak Zelten ist der Zeltstoff mit einer wasserdichten PU Beschichtung von mindestens 1500-4000 mm ausgerüstet. Die Zelte sind mit einem hochwertigen Nahtband thermisch wasserdicht versiegelt. Die PU Nahtbänder werden auf modernsten Hochfrequenz Maschinen verarbeitet. Das Nahtband gewährt eine lange Haltbarkeit ab 1500 mm PU Beschichtung.

Reißverschlüsse sind Verschleißartikel. Wir verwenden "SBS" Qualitäts-Reißverschlüsse mit einer Querfestigkeit von 600 - 800N. Der High Peak Standard übertrifft die Zelt Norm DIN EN 5912: 200-350 N um ein vielfaches.

Our aim is to constantly optimise our equipment. High Peak tents equipped with waterproof PU coated flysheet fabric minimum 1500 up to 4000 mm. All tents processed with high quality waterproof PU seam tape. The tape is seam sealed by modern high frequency welding machines. The seam tape guarantees durability starting from 1500 mm PU coating.

Zipper known as ware parts. We use only high quality "SBS" with a lateral strength of 600-800 N. The High Peak standard outperforms the tent ISO 5912: 200-350N

INNOVATIONS



# Climate Protection 80

Temperatur Praxis-Test | Temperature Field Test

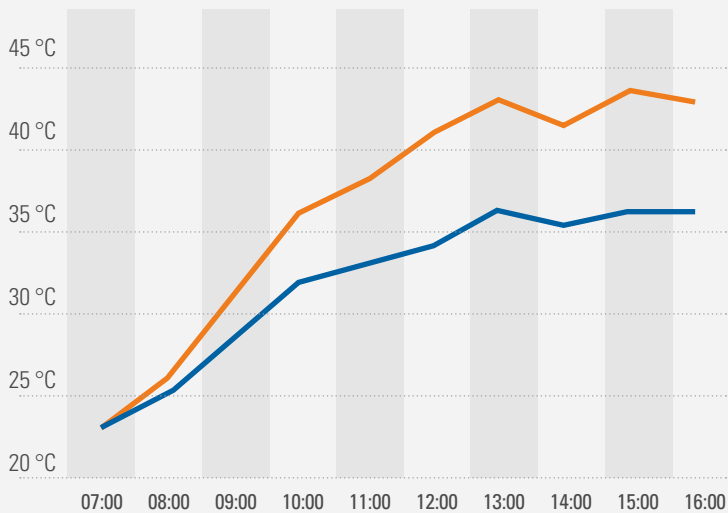

— Nevada 3

— Nevada 3.1



Die neue **Climate Protection 80 Serie** ist mit einer Aluminiumbeschichtung ausgestattet. Die Beschichtung stärkt das Außenzeltgewebe, ist wärmereduzierend und hat einen UV Sonnenschutzfaktor 80 (UV Standard 801).

Dunkle Innenzelte mit Dual Flow Ventilation-System für hohen Schlafkomfort. Klarsichtfenster hellen den Vorbau auf. Die komplette Serie ist mit hochwertigen SBS Markenreißverschlüssen ausgestattet.

The new **Climate Protection 80 series** is equipped with an aluminium coating. The coating strengthens the outer tent fabric, it is heat-reducing and it features an UV sun protection factor 80 (UV Standard 801).

Dark inner tents with Dual Flow ventilation system for sleeping comfort. Transparent windows brighten the porch area. The complete range is equipped with high quality SBS brand zippers.

# Optimales Zeltklima. Technik für Frischluft.

Superior climatic. Fresh air technology.



## Vario Vent Control



## Frischluft im Innenzelt

Das ausgetüftelte Vario-Vent-Control-System lässt sich bequem von innen mittels Reißverschlüssen variabel bedienen. Ein großes Gazefenster bringt Frischluft und kann, wenn es ungemütlich wird, einfach mit der Abdeckklappe verschlossen werden. Die Abdeckklappe lässt man einfach in eine Tasche fallen. Aufrollen passé. Bei geschlossener Abdeckklappe sind zusätzlich 2 Dauerventilationen für die Luftzirkulation vorhanden.

## Fresh air in the inner tent

The ingenious Vario-Vent-Control-System can be comfortably and variably operated from the inside. A large mesh window provides fresh air and, if the weather starts getting uncomfortable, it can be easily closed with the inside flap. Just drop the cover flap into the pocket. Annoying rolling up is thus a thing of the past. If the flap is closed, 2 additional continuous ventilation systems ensure air circulation.



INNOVATIONS



Dual Flow Vent System



Das Dual-Flow-Ventilations-System ist einzigartig.

Variabel zu öffnen mittels Reißverschlüssen. Bei Hitze ventiliert das große Gaze-Fenster perfekt und kann je nach Witterung variabel abgedeckt werden. Schlechtes Wetter ist kein Problem.

Das Gaze-Fenster einfach komplett abdecken. Unter der Abdeckung sorgt die Dual-Flow-Dauerventilation stets für Luftzufuhr.

The Dual Flow ventilation system is unique.

The system can be variably opened by zippers. In hot weather, the large mesh window provides perfect ventilation and can be variably covered depending on the weather. Rainy days is not a problem at all.

Simply cover the entire mesh window. Under the cover, the dual flow continuous ventilation ensures a constant supply of fresh air.



Dauerventilation mit Abstandshalter | Permanent ventilation with distance holder



Dauerventilation mit Abspannfunktion | Permanent ventilation with guy out function

# Leichtgewicht Active Serie

## Lightweight active series



Aluminium Gestänge 7001 T6 |  
Aluminium poles 7001 T6



Leichtgewicht |  
Lightweight



Kleines Packmaß |  
Small pack size



Sehr stabil |  
High stability



Langlebig |  
Durable



Schneller und leichter Aufbau |  
Quick and easy to pitch

Die erfolgreichen **High Peak Active Zelte** Falcon, Goshawk, Siskin, Kite, Sparrow und Woodpecker sind in zwei Varianten erhältlich und glänzen durch ein kleines Packmaß, Vielseitigkeit und die leichte Handhabung.

### **Active Lightweight:**

Hochwertiges Aluminium 7001 T 6 Gestänge  
– Leichte und stabile Aluminium Erdnägel  
– Quick Fix Alu Dreilochspanner

Ideal für Trekking – Rucksackreisen –  
Fahrrad / Motorradtouren und alle Camper,  
die auf unnötiges Gewicht gerne verzichten.

Optional mit flexiblem Fiberglass Gestänge. Ideal für aktives  
Camping und um mit Freunden preisbewusst die Natur zu erleben.

Our successful **High Peak Active tents** Falcon, Goshawk, Siskin, Kite, Sparrow and Woodpecker are available in two different versions. Small packaging, versatile and easy to use.

### **Active Lightweight:**

High quality aluminium 7001 T6 poles  
– Light and strong aluminium pegs  
– Quick Fix alloy guy line adjuster

Great for Trekking – Backpacking –  
Motorcycle/Bike touring and for active  
campers looking for light and functional gear.

Flexible fibreglass poles optional. Ideal for active  
camping with friends enjoying the nature on budget.



# INNOVATIONS



► Gaze-Fenster | Mesh window



► 2 »Advanced Low Vent« System Bodenventilationen | 2 »Advanced Low Vent« System ground ventilations



Aluminium 7001 T6



INNOVATIONS

# Familien-Zelte

## Family tents

Funktionelle Komfort-Campingzelte  
in neuer Optik und mit  
hervorragender Ausstattung.

Functional comfort-camping  
tents in new optic with  
innovative features.

Climate Protection Dach |  
Climate protection roof

Strapazierfähiges  
Qualitäts-Polyester  
4000 mm wasserdicht |  
High quality durable  
polyester fabric  
4000 mm waterproof

Gazetüren |  
Mesh doors



Panorama Fenster mit variabel einstellbaren Gardinen |  
Panoramic clear window with adjustable blinds





Stehhöhe |  
Stand up height



Eingenähter Zeltboden |  
Sewn-in groundsheet



Abgedunkelte  
Schlafkabinen |  
Darkened inner tent

Großzügige, helle Wohnbereiche und variable Innenzelte.  
Die mit **Climate Protection** ausgestatteten Dachbereiche sorgen für Wärmereduzierung im Zelt. Das wetterbeständige und beschichtete Polyester Außenzeltmaterial mit einer Wassersäule von 4000 mm garantiert eine 100 % Wasserdichtigkeit.

Roomy, bright living areas and versatile inner tents.  
The **Climate Protection** equipped roof fabric guarantees heat reduction in the tent. The weather proofed and coated Polyester outer tent fabric with a water column of 4.000 mm guarantees 100 % waterproofness.



**DualFlow**  
Vent System



**INNOVATIONS**

# Innovative Bus-Zelte

## Innovative Drive Away Awnings

Innovative Buszelte mit vielen durchdachten Details für mobilen und flexiblen Einsatz. Variable Anbauhöhen von 170 bis 240 cm.

Innovative Drive Away Awnings with many thoughtful features for mobile and flexible use. Variable attachment heights 170-240 cm.





#### MULTI-KOMPATIBLE FAHRZEUG-ANBINDUNGSSYSTEME:

- Doppel-Keder-Profil 5,8/7,2 mm
- Hohlraum mit Schleusenstab und Klemmen
- Extra starke Klettverschlüsse für Dachreling
- Drei extrabreite, abnehmbare Quick-Fix Dach-Spanngurte
- Drive-Away-Zip System ermöglicht ein leichtes An- und Abdocken am Fahrzeug

#### AUSSTATTUNGSMERKMALE:

- Höhenverstellbare Schleuse mittels Reißverschluss-System
- Aufrollbare Schleuse
- Eingenähter Zeltboden
- Freistehend
- Quick Fix Sicherheits-Sturmbänder
- Strapazierfähiges Qualitäts-Polyester 4000 mm wasserdicht

#### MULTI-KOMPATIBLE CAR CONNECTOR-SYSTEMS:

- Pre-attached double kador strip 5,8/7,2 mm
- Sleeve for pole bar and clamps or guy lines
- Three velcro touch fastener for roof bar attachments
- Quick Fix over vehicle webbing straps
- Drive Away Zip system makes it easy to attach/detach the awning

#### FEATURES:

- Adjustable connector height by zipper-system
- Roll away connector tunnel
- Sewn-in groundsheet
- Self-supporting
- Quick Fix storm straps
- Durable high-quality polyester fabric 4000 mm waterproof



- ▶ Doppelkeder | Double kador strip
- ▶ Hohlraum-Schleusenstab | Sleeve pole



- ▶ 3 Klettbandschlaufen für Dachreling | 3 touch fastener roof bar attachment tabs



- ▶ Abnehmbarer Keder mittels RV: leichtes An-/Abdocken | Drive away zip system



- ▶ 3 extra breite 5 cm Quick Fix Dachbänder | 3 extra wide 5 cm quick fix roof bands

# Gut gebettet, gut geschlafen.

## Bed right, sleep tight.



### Dura Loft®

- Beste Wärmeisolierung
- Isolieren auch noch in feuchtem Zustand
- Schnelltrocknend
- Silikonisiert
- Pflegeleicht
- Geeignet für Allergiker

### Dura Loft® H1

Sehr robuste Füllung bestehend aus 2 Komponenten:

- 6D Hohlfaser zur optimalen Wärmespeicherung
- 6D Vollfaser zur Stabilisierung.

Dura Loft H1 verwenden wir für unsere „Camping Line“

und Einstieg „Active Eco Line“. Highly durable filling consisting of 2 components:

- 6D hollow fiber for optimal heat retaining
- 6D full fiber for stabilization

We incorporate Dura Loft H1 in our “Camping Line” and entry level “Active Eco Line”.

### Dura Loft® 3D SPIRAL

Hochleistungs-Spiralfaser-Füllung, bestehend aus 4 Komponenten:

- 1,5D Spiral-Leichtgewicht-Vollfaser zur Gewichtsminimierung
- 3D Spiral-Hohlfaser zur optimalen Wärmespeicherung
- 3D Spiral-Vollfaser zur Stabilisierung
- 4D Vollfaser zur thermischen Versiegelung

Für beste Wärmeleistung und Haltbarkeit werden alle Komponenten thermisch versiegelt. Die spiralförmige Faser hat eine sehr hohe Rückstellkraft und entwickelt den ursprünglichen Loft sofort, nachdem der Schlafsack dem Packsack entnommen wird, in dem er zuvor stark komprimiert wurde. Dura Loft 3D Spiral wird ausschließlich für unsere Performance Serie Hyperion verwendet.

High-performance spiral fiber filling, consisting of 4 components:

- 1,5D spiral-lightweight full fiber for weight minimization
- 3D spiral hollow fiber for optimal heat retaining
- 3D spiral full fiber for stabilization
- 4D Full fiber for thermal sealing

All components are thermally sealed for highest thermal capacity and durability.

The spiral-shaped fiber has a very high restoring force, restoring the original loft once the sleeping bag has been removed from the packsack, in which it had been highly compressed. Dura Loft 3D Spiral is exclusively used for our performance series Hyperion.

- Highest thermal insulation
- Retention of insulating properties even when moist
- Fast drying

- Siliconized
- Low-maintenance
- Suitable for persons suffering from allergies

### Dura Loft® H4

Hochbausch Füllung bestehend aus 2 Komponenten:

- 6D 4-Kanal- Hohlfaser zur optimalen Wärmespeicherung
- 6D Vollfaser zur Stabilisierung

Für beste Isolierung und Bausch Kraft (Loft). Unsere bestens bewährte Dura Loft H 4 Faser Füllung wird für unsere „Performance Line“ eingesetzt.

Super loft filling consisting of 2 components:

- 6D 4- channel hollow fiber for optimal heat retaining
- 6D full fiber for stabilization

The 4 channel fiber offers the highest degree of insulation and optimum fill power (loft). Our truly proven Dura Loft H 4 filling is used for our “Performance Line”.

### Dura Loft® DENSITY

Leichtgewicht Füllung aus 3 Komponenten:

- 0,78D Mikrofaser zur Gewichtsminimierung
- 3D Powerloft Vollfaser zur Stabilisierung und optimale Loft
- 4 D Vollfaser zur thermischen Versiegelung

Sehr leicht zu komprimieren für kleinstes Packmaß. Gutes Isolations-Gewichtsverhältnis. Die Füllung wird thermisch versiegelt. Dura Loft Density wird bei unseren „Active Eco Line“ PAK 600 ECO und PAK 1000 ECO eingesetzt.

Lightweight filling consisting of 3 components:

- 0,78D micro fiber for weight minimization
- 3D Powerloft full fiber for stabilization and optimum loft
- 4D Full fiber for thermal sealing

Very easy to compress to achieve smallest pack size possible. Good insulation – weight ratio. The filling is thermally sealed. Dura Loft Density is used for our “Active Eco Line” PAK 600 ECO and PAK 1000 ECO.



## OEKO-TEX® STANDARD 100

OEKO-TEX® ist ein unabhängiges Prüfinstitut - und Zertifizierungssystem für textile Produkten in allen Verarbeitungsstufen.

Für die Zertifizierung von recycelten Materialien mit dem OEKO-TEX® STANDARD 100 gelten eine effektives Qualitätsmanagement und strenge Regeln. Das Polyester Füllmaterial ist aus 100 % recyceltem Polyester „Post-Consumer-Material, PET- Flaschen und Fasern“.

OEKO-TEX® is an independent testing institute and certification system for textile products in all processing stages.

The certification of recycled materials with the OEKO-TEX® STANDARD 100 is subject to effective quality management and strict rules. The polyester filling material is made of 100 % recycled polyester “ post-consumer material, PET bottles and fibres”.

Der GRS verfolgt das Ziel, den Anteil an recycelten Materialien in einem Produkt zu erhöhen. Der Standard ermöglicht es Unternehmen, den genauen Anteil an recyceltem Material in einem Produkt zu erfassen und durch die Produktionskette weiter zu verfolgen. Ferner sollen ökologische und chemische Risiken minimiert werden. Das Polyester für den Außen- Innenbezug ist aus 100 % Post-Consumer-Material, recyceltem Polyesterfasern“.

The GRS pursues the goal of increasing the proportion of recycled materials in a product. The standard allows companies to record the exact proportion of recycled material in a product and track it further through the production chain. Furthermore, ecological and chemical risks should be minimized.

The polyester for the exterior and interior cover is made of 100 % post-consumer material, recycled polyester fibres.

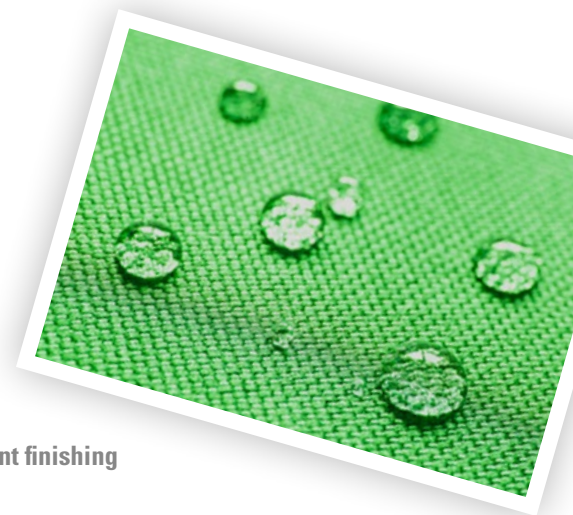

## BIONIC FINISH® ECO



### BIONIC-FINISH® ECO ecology and pioneering, textile water repellent finishing

RUCO-DRY ECO PLUS was developed based on a technology which is environmentally friendly and fluorine-free using highly branched polymers, and already belongs to the 3rd generation of products based on fluorine-free formulas. It conveys higher efficiency combined with better permanence and sustainability.

### BIONIC-FINISH® ECO – Ökologie und zukunftsweisende textile Hydrophobierung

RUCO-DRY ECO PLUS wurde auf Basis einer umweltfreundlichen fluorfreien Technologie mit hochverzweigten Polymeren entwickelt und gehört bereits zur 3. Generation von Produkten, die auf fluorfreien Rezepturen basieren. Es vermittelt höhere Effizienz, verknüpft mit besserer Permanenz und Nachhaltigkeit.



### Ökologische Nachhaltigkeit | Environmental sustainability

High Peak setzt sich bewusst für ökologische Nachhaltigkeit ein. Unsere Schlafsäcke sind PFC frei.

High Peak is committed to environmental sustainability. Our sleeping bags are PFC free.



# Active Eco Line

## Schlafsäcke | Sleeping bags

Die High Peak Active ECO Line steht für:

- Recycelte Materialien
- Einhaltung ökologischer und sozialer Kriterien
- Umweltfreundliche Produktion der Materialien
- Schonung fossiler Ressourcen
- Nachhaltiges Chemiemangement

Die Active ECO Recycle Serie erfüllt folgende Kriterien:

**Außenbezug:** 100 % Polyester recycelt und „Global Standard Recycled“ zertifiziert. Die Materialien werden aus wiederaufbereiteten Fasern gewonnen. Wasser und schmutzabweisend mit BIONIC-FINISH®ECO ausgerüstet, eine umweltfreundliche und PFC freie Technologie.

**Innenbezug:** 100 % Polyester recycelt, „Global Standard Recycled“ zertifiziert. Die Materialien werden aus wiederaufbereiteten Fasern gewonnen. Atmungsaktiv und hautsympathisch.

**Füllungen:** 100 % Polyester, recycelt, „OEKO-TEX Standard 100“ zertifiziert. Die Materialien werden aus wiederaufbereiteten Fasern und rPET Flaschen gewonnen.



The High Peak Active ECO Line stands for:

- Recycled materials
- Compliance with ecological and social criteria
- Environmentally friendly production of materials
- Saving fossil resources
- Sustainable chemical management

The Active ECO Recycle series meet the following criteria:

**Shell:** 100 % Polyester recycled and “Global Standard Recycled” certified. The materials are obtained from post-consumer filaments. Water and dirt-repellent equipped with BIONIC-FINISH®ECO, an environmentally friendly and PFC-free technology.

**Lining:** 100 % Polyester recycled, “Global Standard Recycled” certified. The materials are obtained from post-consumer filaments. Breathable and skin-friendly.

**Filling:** 100 % Polyester, recycled, »OEKO-TEX Standard 100“ certified. The materials are obtained from post-consumer filaments and rPET bottles.

## ZIELGRUPPE | TARGET GROUP

Aktives Camping, Rucksacktouren,  
Sommertrekking, Wandern und Reisen |  
Active camping, backpacking,  
summer trekking, hiking and travel

## EIGENSCHAFTEN | FEATURES

Leichtgewicht, Kompakt, Funktional |  
Lightweight, compact, functional

## EINSATZBEREICH | APPLICATION

Frühjahr / Sommer  
Temperatur Limit bis +3 °C EN ISO-23537-1:2016 |  
Spring / summer  
Temperature limit to +3 °C EN ISO-23537-1:2016

Füllung 100 % Polyester recycelt |  
Filling 100 % Polyester recycled

Außenbezug recycelt, wasser- und schmutzabweisend  
PFC-freie Ausrüstung |  
Outer shell recycled, water and dirt-repellent  
PFC-free finish

Innenfutter, recycelt, atmungsaktiv |  
Lining, recycled, breathable



Reißverschluss-Abdeckleiste  
mit Einkemmschutz |  
Zip baffle with anti snag guard

Verstellbare Kontur-Kapuze |  
Adjustable shaped hood

Zwei-Wege Auto Lock Reißverschluss |  
Two way auto lock zipper



**PAK 600 ECO**

**PAK 1000 ECO**

**BLACK ARROW ECO**

**ULTRA PAK 500 ECO**



# Performance Line

## Schlafsäcke | Sleeping bags

Die High Peak Performance Serie glänzt durch technische Innovationen, hohem Komfort und großem Einsatzbereich.

Ausschließlich strapazierfähige, leichte Stoffe und hochwertige Dura Loft® Hightech Faserfüllungen mit besten Isolationseigenschaften werden für die Performance Serie verwendet.

Das enganliegende Kopfteil schützt den empfindlichen Kopf vor Kälte. Die funktionale Reißverschluss-Abdeckleiste mit Antiklemmschutz verhindert Kältebrücken und ein Verhaken des Reißverschlusses. Der Kompressionspacksack reduziert das Packvolumen.

High Peak setzt sich bewusst für ökologische Nachhaltigkeit ein und vermeidet den Einsatz von umweltschädlichen Perfluorcarbonen (PFC) bei wasserabweisenden Beschichtungen.

The High Peak Performance range stands for technical innovations, great comfort and a wide range of applications.

Exclusively durable, lightweight fabrics and high-quality Dura Loft® innovative insulation fibres with high thermal capacity are used for the Performance range.

The adjustable 3 D hood design keeps the head and shoulder warmer during the night. High functionality with zip baffle reduces cold spots for optimal insulation and the zipper anti snag guard prevents the zip from snagging on the lining. The compression-sac reduces the packing to a minimum.

High Peak is consciously committed to ecological sustainability and avoids the use of environmentally harmful perfluorocarbon's (PFC) in water-repellent coatings



## ZIELGRUPPE | TARGET GROUP

Camping, Trekkingtouren,  
Bergtouren, Rucksacktouren |  
Camping, trekking,  
backpacking, mountain hiking

## EIGENSCHAFTEN | FEATURES

Hohe Isolationswerte, aufwendige Konstruktionen,  
hervorragende Funktionalität |  
Excellent insulation performance,  
extensive constructions, top functionality

## EINSATZBEREICH | APPLICATION

Frühjahr / Sommer / Herbst  
Temperatur Limit bis -6 ° C EN ISO-23537-1:2016 |  
Spring / summer / autumn  
temperature limit up to -6 ° C EN ISO-23537-1:2016

Außenbezug wasser- und schmutzabweisend  
PFC-freie Ausrüstung |  
Outer shell water and soil repellent  
PFC-free finish



Ergonomisch geformter  
Auto-Lock-Reißverschluss |  
Ergonomic shaped auto-lock zipper



Verstellbare Kontour-Kapuze |  
Adjustable shaped hood

Innenfutter, atmungsaktiv |  
Lining, breathable



Reißverschluss-Abdeckleiste |  
Zip baffle

Einklemmschutz |  
Anti snag guard

Ergonomisches Fußteil |  
Ergonomic foot box





# Camping Line

## Schlafsäcke | Sleeping bags

Die High Peak Schlafsack Camping Serie mit optimalem Preis-Leistungs-Verhältnis. Ideal für Camping, Festival und den Besuch bei Freunden.

Die attraktiven Campingschlafsäcke sind mit der hochwertigen Dura Loft® H1 Füllung ausgestattet und bieten einen hohen Schlafkomfort und viel Bewegungsfreiheit.

High Peak setzt sich bewusst für ökologische Nachhaltigkeit ein und vermeidet den Einsatz von umweltschädlichen Perfluorcarbonen (PFC) bei wasserabweisenden Beschichtungen.

The High Peak sleeping bag camping range offers incredible value for money. Ideal for camping, festivals and occasional visiting friends.

The attractive camping sleeping bags are equipped with the high-grade Dura Loft® H1 filling and offer great sleeping comfort and plenty space for freedom of movement.

High Peak is consciously committed to ecological sustainability and avoids the use of environmentally harmful perfluorocarbon's (PFC) in water-repellent coatings.

## ZIELGRUPPE | TARGET GROUP

Camping, Festivals, Freizeit-Camper |  
Camping, festival, free time camper

## EIGENSCHAFTEN | FEATURES

Viel Platz für mehr Bewegungsfreiheit, Komfort |  
Extra space for greater freedom of movement, comfort

## EINSATZBEREICH | APPLICATION

**Deckenschlafsäcke:** Sommer /  
Temperatur Limit bis +14 °C EN ISO 23537-1:2016 |  
**Square shaped sleeping bags:** Summer /  
Temperature limit up to +14 °C EN ISO 23537-1:2016

Extra langer Zwei-Wege  
Reißverschluss bis zum Fußende |  
Extra long two-way zip around foot

Doppel-Decken-Funktion |  
Double-blanket-function



Polyester Außenbezug  
wasser- und schmutzabweisend -  
PFC-freie Ausrüstung |  
Polyester shell water and soil  
repellent - PFC-free finish

Polyester Innenfutter, atmungsaktiv |  
Polyester lining, breathable

## EINSATZBEREICH | APPLICATION

**Mumienschlafsäcke:** Frühjahr / Sommer /  
Temperatur Limit Comfort bis +5 °C EN ISO-23537-1:2016 |  
**Mummy shaped sleeping bags:** Spring / summer /  
temperature limit comfort up to +5 °C EN ISO-23537-1:2016

Polyester Außenbezug wasser- und schmutzabweisend – PFC-freie Ausrüstung |  
Polyester shell water and soil repellent – PFC-free finish

Reißverschluss-Abdeckleiste |  
Zip baffle

Polyester Innenfutter, atmungsaktiv |  
Polyester lining, breathable



Verstellbares Kopfteil |  
Adjustable hood



Zwei-Wege-Reißverschluss |  
Two-way zipper



# High Tech Matten

## High tech mats

### Neuartige Wellenoberseite „Wave Cut“

Die von High Peak neu entwickelten, selbstaufblasbaren Thermomatten haben eine neuartige Wellenoberseite, die wir „Wave Cut“ Konstruktion nennen. Die dynamische Trapezform bietet höchsten Komfort, einfache Handhabung und ist gewichtssparend. Die Wellenoberseite passt sich für besten Liegekomfort perfekt dem Körper an. Die Oberseite ist aus hautsympathischem Anti-Rutsch Polyester mit einem technischen Honeycomb Druck. Die Unterseite ist aus strapazierfähigem, Anti-Rutsch 150 D Polyester. Die Matten lassen sich mühelos aufrollen und wieder verpacken.



### Newly developed „Wave Cut“

Our newly developed High Peak „Wave Cut“ self-inflatable mats in dynamic trapeze shape feature comfortability, easy handling and weight saving. The “Wave Cut” punched top snuggling perfectly your body for sweet dreams and pack easy. The upper material is made of skin friendly anti slip polyester with a technical honeycomb print. The bottom feature durable 150 D anti slip polyester. The mats can be effortlessly rolled up and repacked.

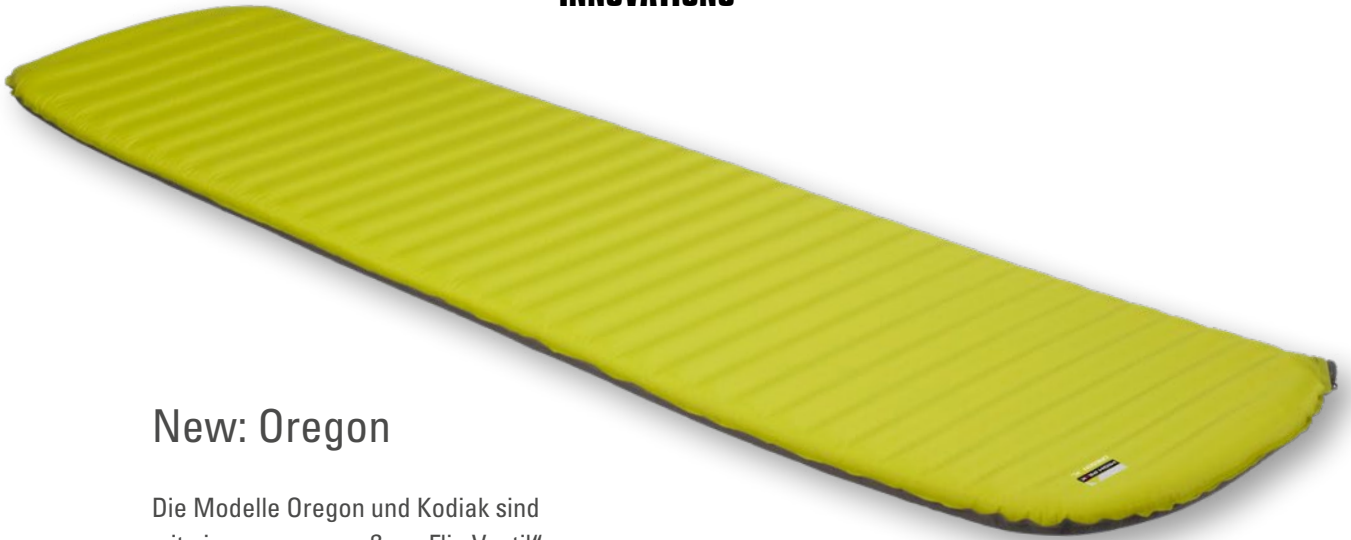

## New: Oregon

Die Modelle Oregon und Kodiak sind mit einem neuen großen „Flip Ventil“ ausgestattet.

Die große Ventilöffnung zieht sofort Luft an und füllt den Schaum für den schnellen Einsatz. Beim Einpacken entweicht die Luft schneller und erleichtert das Aufrollen.

Alle Matten sind in Überlängen und in verschiedenen Breiten erhältlich.

Our Oregon and Kodiak mats feature a new flip valve.

The flip valve instantly draws air and fills the foam for quick use and the air escapes faster and makes it easier to roll up.

All mats available in overlengths and different widths.

## Flip Ventil | Flip valve



Aufblasmodus |  
Inflate mode



Wechselmodus |  
Switch mode



Ablassmodus |  
Deflate mode

Große Ventilöffnung zieht sofort Luft an und füllt den Schaum. Beim Einpacken entweicht die Luft schneller und erleichtert das Aufrollen.

Oversized valve opening immediately draws air and fills the foam. When packing the air escapes faster and facilitates the rolling up.



Video



## Leichtgewichtmatratzen.

Unsere Leichtgewichtmatratzen Denver, Dallas und Dallas Twin sind mit einem neuen extra großen Ventil ausgestattet. Die große Ventilöffnung dient zur schnellen Befüllung und Luftentweichung. Dadurch wird das Einrollen der Matratze deutlich einfacher und schneller.

Die 23 horizontalen Kammern bieten höchsten Schlafkomfort und ein angenehmes Liegegefühl. Das lästige Schwanken wie bei herkömmlichen Luftmatratzen ist passé. Die 10 cm hohen Luftkammern garantieren eine gute Isolation. Für die Dallas Serie und Denver verwenden wir hochwertiges, hautsympathisches Anti-Rutsch Polyester mit technischem Honeycomb Druck.

High Peak hat eigene Formen in Übergrößen bzw. Überbreiten entwickelt. Diese eignen sich besonders für große Personen bzw. können von zwei Personen genutzt werden.

Das Ergebnis sind Matratzen in Komfortgrößen, die zugleich leicht sind und ein kleines Packmaß haben. Die integrierte Pumpe füllt die Matratze schnell.

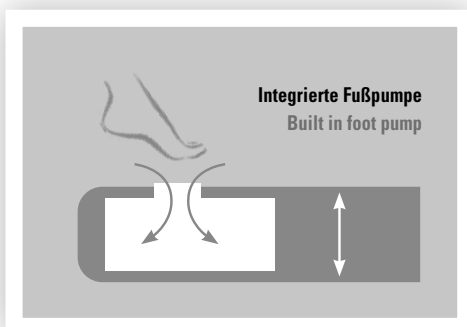

## Lightweight mattresses.

Our advanced lightweight mattresses Denver, Dallas, Dallas Twin feature a newly developed oversized pad valve. The oversized valve opening get the air fast out and make the mats much easier and quicker to roll and pack.

The 23 horizontal air chambers offer the ultimate sleeping comfort. Bothersome swaying of conventional air mattresses is truly a thing of the past. The 10 cm high air chambers ensure good insulation. Our models Denver, Dallas, Dallas Twin Series are made of high quality 190T brushed polyester; skin friendly and anti slip with a technical honeycomb print.

High Peak has its own designs in oversized length and width. The High Peak new lightweight mattresses perform in comfortable sizes and small pack size. The integrated foot pump inflates the mattresses very quick and easy.



Große Ventilöffnung zur schnellen Befüllung und Luftentweichung. Das Einrollen der Matratze ist deutlich einfacher und schneller.

Oversized valve opening for quick filling and air release. Rolling up the mattress is much easier and faster.



Video



## FEATURES

# CROSS-BEAM Luftbetten CROSS-BEAM air beds

### HIGH PEAK Luftbetten setzen neue Maßstäbe in Konstruktion – Funktion – Design

Die von uns neu entwickelten CROSS-BEAM Luftbetten mit horizontalen Kammern bieten höchsten Schlafkomfort und ein angenehmes Liegegefühl. Das lästige Schwanken wie bei herkömmlichen Luftmatratzen ist passé.

HIGH PEAK hat für die CROSS-BEAMS eigene Formen entwickelt. Die neuen HIGH PEAK CROSS-BEAM Luftbetten sind in Überlängen erhältlich und werden mit unseren neu entwickelten Anti-Rutsch-Pads (Geschmacksmuster) ausgerüstet. Die Oberseite ist aus hautsympathischer, organischer Viskose und attraktivem Waben-Transparentdruck. Mit der integrierten Pumpe ist das Luftbett minutenschnell aufgeblasen.

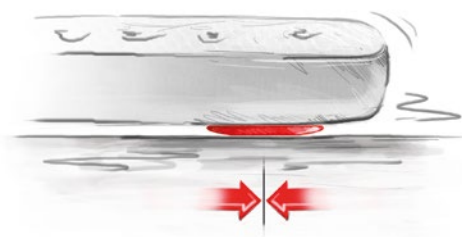

### HIGH PEAK air beds set new standards in construction – function – design.

The newly developed CROSS-BEAM air beds by HIGH PEAK with cross air chambers offer the ultimately sleeping comfort. The bothersome swaying of conventional air mattresses is truly a thing of the past. HIGH PEAK developed own moulds for the CROSS-BEAM construction. Our CROSS-BEAM air beds are available in extra long sizes and are provided with our newly developed anti-slip pads (design patent). The HIGH PEAK air beds provide a skin-friendly surface made of organic rayon and attractive honey-comb transparent print. Our styles with built in pump inflates the air beds very quickly and easily.



video

# Camping Serie

## Camping series

### ZIELGRUPPE | TARGET GROUP

Camping – Festival

### EIGENSCHAFTEN | PERFORMANCE

Funktionell – vielseitig | Functional – versatile

### EINSATZBEREICH | APPLICATION

2-3 Jahreszeiten | 2-3 Seasons

### AUSSTATTUNG | FEATURES

- ▶ PFC freie wasserabstoßende Imprägnierung (DWR) | PFC free water-repellent impregnation (DWR)
- ▶ Nathversiegelt, wasserdicht | Seam sealed, waterproof
- ▶ Aluminium Beschichtung UV Protect 80 (UV Standard 801) wärmereduzierend | Aluminium coating UV protect 80 (UV standard 801)
- ▶ Advanced Low Vent System | Advanced Low Vent System
- ▶ Wettergeschützter Eingang | Weather protected entrance
- ▶ Dauer-Ventilationssystem | Permanent ventilation
- ▶ Klarsichtfolienfenster | Crystal clear windows
- ▶ „SBS“ Reißverschluss, Querfestigkeit 600-800 N | „SBS“ zipper, lateral strength 600-800 N
- ▶ Reißverschluss- Abdeckklappen | Zipper cover

### PREMIUM AUSSTATTUNG | PREMIUM FEATURES

- ▶ Vorbau mit Zeltboden und Faulstreifen | Vestibule with ground sheet and mudflap
- ▶ Klarsichtfolienfenster mit Abdeckung | Crystal clear windows with cover





Funktionaler, seitwärts zu öffnender Eingang ohne Höhenverlust | Functional sideways to open entry without loss of door height

Strapazierfähiges Qualitäts-Polyester 3000 mm wasserdicht mit PFC freier, wasserabstoßender Imprägnierung (DWR) | Durable quality Polyester 3000 mm waterproof, PFC free water-repellent impregnation (DWR)

Climate Protection 80 Aluminium Beschichtung, Wärmereduzierung, UV Schutzfaktor 80 | Climate Protection 80 aluminium coating, heat reflective, UV protection 80



Zeltboden und Faulstreifen | Ground sheet and mudflap



Dauerventilation mit Abstandshalter | Permanent ventilation with distance holder



Vario Vent Control Eingang mit Gazefenster | Vario Vent Control entry with mesh window

Abgedunkeltes Innenzelt | Darkened inner tent



Advanced Low Vent System

Klarsicht-Folienfenster mit Abdeckung | Crystal Clear window with cover



Dauerventilation mit Abspannfunktion | Permanent ventilation with guy out function



Abgedunkeltes Innenzelt | Darkened inner tent

Vario Vent Control Eingang mit Gazefenster | Vario Vent Control entry with mesh window

Advanced Low Vent Belüftung mit Abdeckklappe | Advanced Low Vent ventilation with cover

## NEVADA

Kuppelzelt mit Vorbau |  
Dome tent with vestibule

- ▶ Dunkelgrün | Deep forest
- ▶ 190T Polyester Alu UV Protect 80, PFC frei | free
- ▶ PE Boden | Groundsheet
- ▶ Fiberglass
- ▶ SBS Marken Reißverschluss | SBS brand zipper
- ▶ Reißverschluss Tragetasche PFC frei | Zipped carry bag PFC free
- ▶ Extra starke 5 mm Erdhügel | Durable, strong 5 mm pegs



## Außenzelt | Fly sheet

- ▶ Advanced Low Vent System Bodenventilation | Advanced Low Vent System ground ventilation
- ▶ Wettergeschützter Eingang | Weather protected entrance
- ▶ Vorbau mit Stauraum | Vestibule and storage
- ▶ Klarsichtfolien-Fenster mit Abdeckung | Crystal clear window with cover
- ▶ Funktionaler seitwärts zu öffnender Eingang ohne Höhenverlust | Functional entry with side opening to avoid entry height level
- ▶ 2 Dauerventilationen mit Abstandshalter | 2 permanent ventilations with distance holder
- ▶ Gestänge Markierung | Color marked poles

## Innenzelt | Inner tent

- ▶ Schwarz eingefärbetes Innenzelt | Black colored inner tent
- ▶ Advanced Low Vent System Bodenventilation | Advanced Low Vent System ground ventilation
- ▶ Vario Vent Control Eingang | Vario Vent Control entry
- ▶ Wannboden | Tub floor
- ▶ Innentaschen | Inner pockets
- ▶ Lampenhalter | Lamp holder



Video

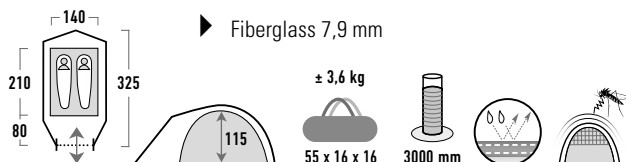

## NEVADA 2.1

Art.-Nr./No. **10350** | EAN **4001690103503** | VPE/PU 4

## NEVADA 3.1

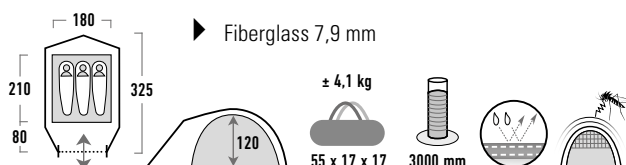
Art.-Nr./No. **10351** | EAN **4001690103510** | VPE/PU 4

## NEVADA 4.1

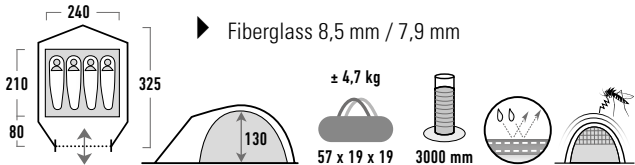
Art.-Nr./No. **10352** | EAN **4001690103524** | VPE/PU 4

# KIRA

## Kuppelzelt mit Tunnel-Vorbau | Dome tent with tunnel shaped vestibule

- ▶ Dunkelgrün | Deep forest
- ▶ 190T Polyester Alu UV Protect 80,
- ▶ PFC frei | free
- ▶ PE Boden | Groundsheet
- ▶ Fiberglass
- ▶ SBS Marken Reißverschluss |
- ▶ SBS brand zipper
- ▶ Reißverschluss Tragetasche PFC frei |
- ▶ Zipped carry bag PFC free
- ▶ Extra starke 5 mm Erdnägel |
- ▶ Durable, strong 5 mm pegs



### Außenzelt | Fly sheet

- ▶ Advanced Low Vent System Bodenventilation |
- ▶ Advanced Low Vent System ground ventilation
- ▶ Wettergeschützter Eingang | Weather protected entrance
- ▶ Vorbau mit Stauraum | Vestibule and storage
- ▶ Zeltboden | Groundsheet
- ▶ Klarsichtfolien-Fenster mit Abdeckung | Crystal clear window with cover
- ▶ Seiteneingang mit Reißverschluss Einfassband nahtversiegelt |
- ▶ Side entry with zipper fabric tape seamsealed
- ▶ Funktionaler seitwärts zu öffnender Eingang ohne Höhenverlust |
- ▶ Functional entry with side opening to avoid entry height level
- ▶ 2 Dauerventilationen mit Abstandshalter |
- ▶ 2 permanent ventilations with distance holder
- ▶ Gestänge Markierung | Color marked poles

### Innenzelt | Inner tent

- ▶ Schwarz eingefärbetes Innenzelt | Black colored inner tent
- ▶ Advanced Low Vent System Bodenventilation |
- ▶ Advanced Low Vent System ground ventilation
- ▶ Vario Vent Control Eingang | Vario Vent Control entry
- ▶ Wannenförmiger Boden | Tub floor
- ▶ Innentaschen | Inner pockets
- ▶ Lampenhalter | Lamp holder



Video



## KIRA 3.1

Art.-Nr./No. **10371** | EAN **4001690103718** | VPE/PU 4

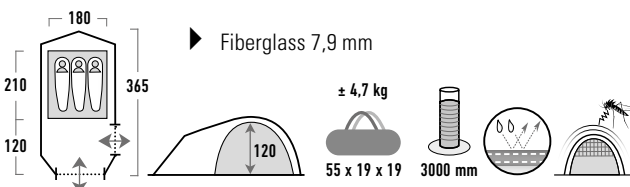

## KIRA 4.1

Art.-Nr./No. **10374** | EAN **4001690103749** | VPE/PU 4

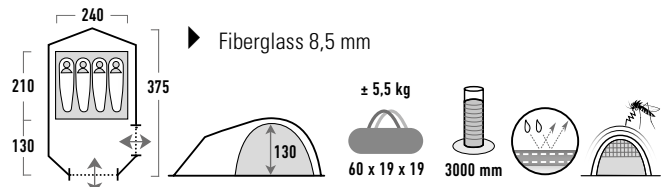

## TESSIN

**Kuppelzelt mit Tunnel-Vorbau |  
Dome tent with tunnel shaped vestibule**

- ▶ Dunkelgrün | Deep forest
- ▶ 190T Polyester Alu UV Protect 80, PFC frei | free
- ▶ PE Boden | Groundsheet
- ▶ Fiberglass 9,5 mm
- ▶ SBS Marken Reißverschluss | SBS brand zipper
- ▶ Reißverschluss Tragetasche PFC frei | Zipped carry bag PFC free
- ▶ Extra starke 5 mm Erdnägel | Durable, strong 5 mm pegs

**Außenzelt | Fly sheet**

- ▶ Advanced Low Vent System Bodenventilation | Advanced Low Vent System ground ventilation
- ▶ Wettergeschützter Eingang | Weather protected entrance
- ▶ Vorbau mit Wohnfläche u. Stauraum | Vestibule with living area and storage
- ▶ Zeltboden | Groundsheet
- ▶ Seiteneingang mit Reißverschluss Einfassband nahtversiegelt | Side entry with zipper fabric tape seamsealed
- ▶ Klarsichtfolien-Fenster mit Abdeckung | Crystal clear window with cover
- ▶ 3 Dauerventilationen | 3 permanent ventilations
- ▶ Gestänge Markierung | Color marked poles



Video

**Innenzelt | Inner tent**

- ▶ Schwarz eingefärbetes Innenzelt | Black colored inner tent
- ▶ Advanced Low Vent System Bodenventilation | Advanced Low Vent System ground ventilation
- ▶ Vario Vent Control Eingang | Vario Vent Control entry
- ▶ Wannboden | Tub floor
- ▶ Innentaschen | Inner pockets
- ▶ Lampenhalter | Lamp holder

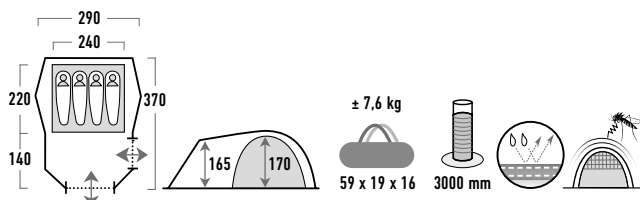
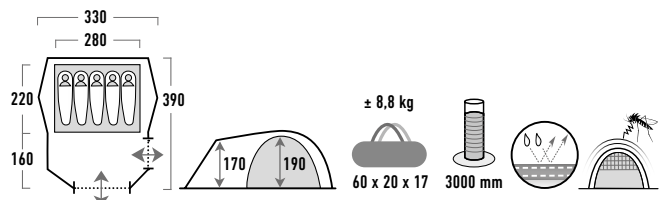
**TESSIN 4.1**Art.-Nr./No. **10380** | EAN **4001690103800** | VPE/PU 2**TESSIN 5.1**Art.-Nr./No. **10381** | EAN **4001690103817** | VPE/PU 1

# VARIO VENT CONTROL



## Frischluft im Innenzelt

Das ausgetüftelte Vario-Vent-Control-System lässt sich bequem von innen mittels Reißverschlüssen variabel bedienen. Ein großes Gazefenster bringt Frischluft und kann, wenn es ungemütlich wird, einfach mit der Abdeckklappe verschlossen werden.

Die Abdeckklappe lässt man einfach in eine Tasche fallen. Aufrollen passé. Bei geschlossener Abdeckklappe sind zusätzlich 2 Dauerventilationen für die Luftzirkulation vorhanden.

## Fresh air in the inner tent

The ingenious Vario-Vent-Control-System can be comfortably and variably operated from the inside. A large mesh window provides fresh air and, if the weather starts getting uncomfortable, it can be easily closed with the inside flap.

Just drop the cover flap into the pocket. Annoying rolling up is thus a thing of the past. If the flap is closed, 2 additional continuous ventilation systems ensure air circulation.



# ADVANCED LOW VENT SYSTEM



Dieses System ist eine sehr effektive Bodenventilation und zirkuliert die Luft im Bodenbereich an zwei Seiten auch bei schlechtem Wetter. Der extra große Abstand zwischen Außenzelt und Innenzelt reduziert Kondensation. Das System wird mittels öffnen der Gaze-Abdeckklappe bequem von der Innenseite aktiviert. Die Abdeckung wird in einer Tasche verstaut und muss nicht aufgerollt werden. Pfiffig ist die Bedienung vom Innenzelt mittels Reißverschluss. Das Ventilationssystem ist bequem von Ihrem kuscheligen High Peak Schlafsack aus zu regulieren.

This System is a highly effective ground level ventilation circulating air throughout the floor area on two sides. The extra space between outer tent and inner tent minimizes condensation. The System can be activated by opening the mesh cover from inside and store the cover easy in the cover garage. Cool idea to handle the System from the inner tent by zip-opening. The rope ventilation system can comfortably be adjusted from your cozy High Peak sleeping bag.



# Premium Camping

## Premium Camping

### ZIELGRUPPE | TARGET GROUP

Camping – Festival – Familien | Camping – festival – family

### EIGENSCHAFTEN | PERFORMANCE

Premium Camping – Komfort Zelte –  
vielseitig – funktionelles, attraktives Design |  
Premium camping – comfort tents –  
versatile – functional, attractive design

### EINSATZBEREICH | APPLICATION

3 Jahreszeiten | 3 seasons

### AUSSTATTUNG | FEATURES

- ▶ Nahtversiegelt, wasserdicht | Seam sealed, waterproof
- ▶ Vorbau mit Zeltboden und Faulstreifen |  
Vestibule with ground sheet and mudflap
- ▶ Klarsichtfolienfenster mit Abdeckung |  
Crystal clear window with cover
- ▶ Dauer-Ventilationssystem | Permanent ventilation system
- ▶ Vario Vent Control Eingang mit Gaze-Fenster |  
Vario Vent Control entry with mesh window
- ▶ „SBS“ Reißverschluss, Querfestigkeit 600-800 N |  
„SBS“ Zipper, lateral strength 600-800 N
- ▶ Hochwertige, gut sichtbare neongrüne Abspannleinen |  
High grade visible, guy lines in neon green
- ▶ Robuster, extra großer Kompressions-Packsack |  
Oversized, durable compression-pack sack

### PREMIUM AUSSTATTUNG | PREMIUM FEATURES

- ▶ Gazefenster | Mesh window
- ▶ Seiteneingang mit Gazefenster |  
Side door with mesh window
- ▶ Innenzelt mit RV-Trennwand |  
Inner tent with zipped divider

Extra große Ventilation |  
Oversized ventilation



Dauerventilation |  
Permanent ventilation

Strapazierfähiges Qualitäts-Polyester 4000 mm,  
versiegelte Nähte, wasserdicht |  
Durable high grade Polyester 4000 mm,  
seam sealed, waterproof



Zeltboden mit Faulstreifen |  
Ground sheet with mudflap

Klarsicht-Folienfenster mit Abdeckung |  
Crystal clear window with cover

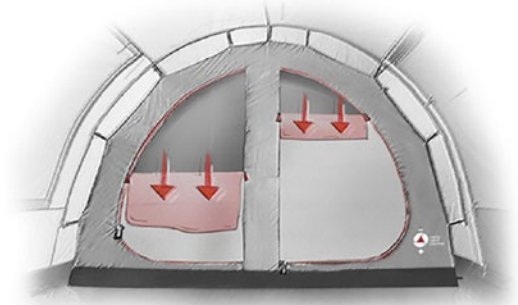

Gazefenster mit RV Abdeckklappe |  
Mesh window with zipper cover



Doppelkabine  
mit RV-Trennwand |  
Twin cabin with  
zipped divider

Großer Wohnraum mit Zeltboden,  
Klarsicht-Folienfenster mit Abdeckung |  
Large living area with ground sheet,  
Crystal clear window with cover

Seiteneingang mit Gaze-Tür |  
Side entry with mesh door

## TALOS

Kuppelzelt mit Vorbau |  
Dome tent with vestibule

- ▶ Dunkelgrau-grün | Dark grey-green
- ▶ 190T Polyester PU
- ▶ Polyester atmungsaktiv | Breathable
- ▶ PE Boden | Groundsheet
- ▶ Fiberglass
- ▶ SBS Marken Reißverschluss | SBS brand zipper
- ▶ Kompressionspacksack | Compression bag
- ▶ Extra starke 5 mm Erdnägel | Durable, strong 5 mm pegs



## Außenzelt | Fly sheet

- ▶ Wettergeschützter Eingang | Weather protected entrance
- ▶ Vorbau mit Stauraum | Vestibule and storage
- ▶ Angenäherter Zeltboden an der Innenzelt Front | Fixed vestibule floor to inner tent front
- ▶ Vorbau mit Faulstreifen | Vestibule incl. mudflap
- ▶ Klarsichtfolien-Fenster mit Abdeckung | Crystal clear window with cover
- ▶ 3 Dauerventilationen mit Abstandshalter | 3 permanent ventilations with distance holder
- ▶ Hochwertige, gut sichtbare neongrüne Abspannleinen | High grade, visible guy lines in neon green
- ▶ Gut sichtbarer neongrüner Bodenstreifen in der Dämmerung | Twilight visible neon green tape around bottom fly sheet
- ▶ Gestänge Markierung | Color marked poles

## Innenzelt | Inner tent

- ▶ Vario Vent Control Eingang | Vario Vent Control entry
- ▶ Wannboden | Tub floor
- ▶ Innentaschen | Inner pockets
- ▶ Lampenhalter | Lamp holder



Video



## TALOS 3

Art.-Nr./No. 11505 | EAN 4001690115056 | VPE/PU 2

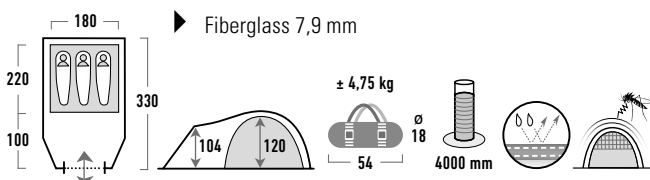

## TALOS 4

Art.-Nr./No. 11510 | EAN 4001690115100 | VPE/PU 2

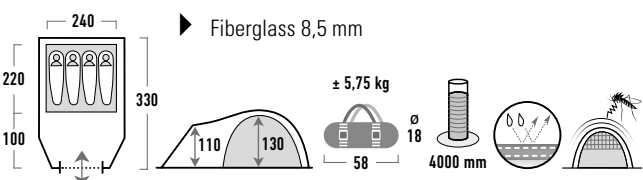



# MESOS 4

## Kuppelzelt mit Tunnel-Vorbau | Dome shaped tent with tunel shaped vestibule

- ▶ Dunkelgrau-grün | Dark grey-green
- ▶ 190T Polyester PU
- ▶ Polyester atmungsaktiv | Breathable
- ▶ PE Boden | Groundsheet
- ▶ Fiberglass 8,5 mm
- ▶ SBS Marken Reißverschluss | SBS brand zipper
- ▶ Kompressionspacksack | Compression bag
- ▶ Extra starke 5 mm Erdnägel | Durable, strong 5 mm pegs



## Außenzelt | Fly sheet

- ▶ Wettergeschützter Eingang | Weather protected entrance
- ▶ Vorbau mit Stauraum | Vestibule and storage
- ▶ Angenähter Zeltboden an der Innenzelt Front | Fixed vestibule floor to inner tent front
- ▶ Vorbau mit Faulstreifen | Vestibule incl. mudflap
- ▶ Seiteneingang mit Reißverschluss Einfassband nahtversiegelt | Side entry with zipper fabric tape seamsealed
- ▶ Klarsichtfolien-Fenster mit Abdeckung | Crystal clear window with cover
- ▶ 3 Dauerventilationen mit Abstandshalter | 3 permanent ventilations with distance holder
- ▶ Hochwertige, gut sichtbare neongrüne Abspannleinen | High grade, visible guy lines in neon green
- ▶ Gut sichtbarer neongrüner Bodenstreifen in der Dämmerung | Twilight visible neon green tape around bottom fly sheet
- ▶ Gestänge Markierung | Color marked poles



Video

## Innenzelt | Inner tent

- ▶ Vario Vent Control Eingang | Vario Vent Control entry
- ▶ Wannenboden | Tub floor
- ▶ Innentaschen | Inner pockets
- ▶ Lampenhalter | Lamp holder



## MESOS 4

Art.-Nr./No. **11525** | EAN **4001690115254** | VPE/PU 2

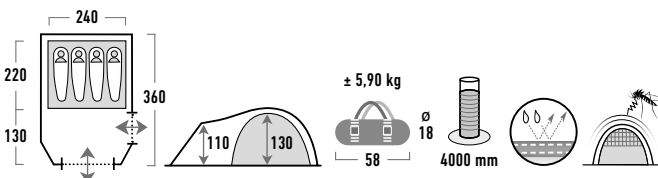

# ATMOS 3

## Tunnelzelt mit Vorbau | Tunnel tent with vestibule

- ▶ Dunkelgrau-grün | Dark grey-green
- ▶ 190T Polyester PU
- ▶ Polyester atmungsaktiv | Breathable
- ▶ PE Boden | Groundsheet
- ▶ Fiberglass 8,5 mm
- ▶ SBS Marken Reißverschluss | SBS brand zipper
- ▶ Kompressionspacksack | Compression bag
- ▶ Extra starke 5 mm Erdnägel | Durable, strong 5 mm pegs



## Außenzelt | Fly sheet

- ▶ Wettergeschützter Eingang | Weather protected entrance
- ▶ Vorbau mit Stauraum | Vestibule and storage
- ▶ Angenähter Zeltboden an der Innentent Front | Fixed vestibule floor to inner tent front
- ▶ Vorbau mit Faulstreifen | Vestibule incl. mudflap
- ▶ Seiteneingang | Side entry
- ▶ Klarsichtfolien-Fenster mit Abdeckung | Crystal clear window with cover
- ▶ Gazefenster mit Abdeckklappe | Mesh window with cover
- ▶ 3 Dauerventilationen mit Abstandshalter | 3 permanent ventilations with distance holder
- ▶ Extra großer Abstand zwischen Außenzelt u. Innentent. Luftzirkulierung | Roomy space between fly sheet and inner tent. Air circulation
- ▶ Hochwertige, gut sichtbare neongrüne Abspannleinen | High grade, visible guy lines in neon green
- ▶ Gut sichtbarer neongrüner Bodenstreifen in der Dämmerung | Twilight visible neon green tape around bottom fly sheet
- ▶ Gestänge Markierung | Color marked poles

## Innentent | Inner tent

- ▶ Vario Vent Control Eingang | Vario Vent Control entry
- ▶ Wannenföden | Tub floor
- ▶ Innentaschen | Inner pockets
- ▶ Lampenhalter | Lamp holder



Video



## ATMOS 3

Art.-Nr./No. 11535 | EAN 4001690115353 | VPE/PU 2

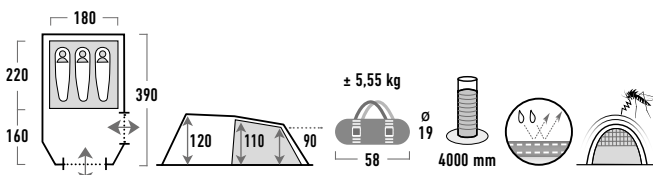

# PAXOS 4

## Familien Tunnelzelt | Family tunnel tent

- ▶ Dunkelgrau-grün | Dark grey-green
- ▶ 190T Polyester PU, 4000 mm
- ▶ Polyester atmungsaktiv | Breathable
- ▶ PE Boden | Groundsheet
- ▶ Fiberglass 9,5 mm
- ▶ SBS Marken Reißverschluss | SBS brand zipper
- ▶ Robuster Roll-down Packsack mit Kompressionsgurten | Durable roll down Packsac with compression straps
- ▶ Extra starke 5 mm Erdnägel | Durable, strong 5 mm pegs



## Außenzelt | Fly sheet

- ▶ Wettergeschützter Eingang | Weather protected entrance
- ▶ Eingänge mit RV Regenrinne und Abdeckklappe | Entrys with zipper rain gusset and zipper flap
- ▶ Vorbau mit Stauraum | Vestibule and storage
- ▶ Angenähter Zeltboden an der Innenzelt Front | Fixed vestibule floor to inner tent front
- ▶ Vorbau mit Faulstreifen | Vestibule incl. mudflap
- ▶ Klarsichtfolien-Fenster mit Abdeckung | Crystal clear window with cover
- ▶ Seiteneingang mit Gaze Fenster mit RV Abdeckklappe | Side entry with mesh window and zippered cover
- ▶ Gazefenster mit RV Abdeckklappe | Mesh window with zippered cover
- ▶ Extra große Ventilation im Schlafbereich mit Abspann Funktion | Oversized ventilation at sleeping area with guy out function
- ▶ 2 Dauerventilationen mit Abstandshalter | 2 permanent ventilations with distance holder
- ▶ Extra großer Abstand zwischen Außenzelt u. Innenzelt. Luftzirkulierung | Roomy space between fly sheet and inner tent. Air circulation
- ▶ Hochwertige, gut sichtbare neongrüne Abspannleinen | High grade, visible guy lines in neon green
- ▶ Gut sichtbarer neongrüner Bodenstreifen in der Dämmerung | Twilight visible neon green tape around bottom fly sheet
- ▶ Gestänge Markierung | Color marked poles



Video

## Innenzelt | Inner tent

- ▶ Abgedunkeltes Innenzelt | Darkened inner tent
- ▶ 2 Vario Vent Control Eingänge | Vario Vent Control entries
- ▶ Wannboden | Tub floor
- ▶ Reißverschluss Trennwand | Zipped divider
- ▶ Organizer
- ▶ Innentaschen | Inner pockets
- ▶ Lampenhalter | Lamp holder
- ▶ Positionsmarkierung passend zum Außenzelt erleichtert das Einhängen | Corresponding color code matching to outer tent for easy set up



## PAXOS 4

Art.-Nr./No. 11508 | EAN 4001690115087 | VPE/PU 1

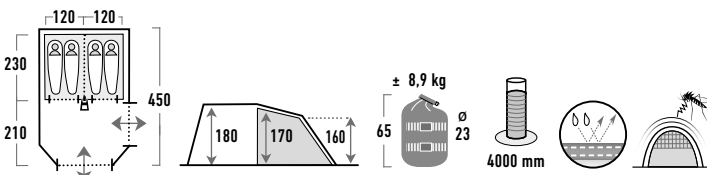

# PAROS 5

## Familien Tunnelzelt | Family tunnel tent

- ▶ Dunkelgrau-grün | Dark grey-green
- ▶ 190T Polyester PU
- ▶ Polyester atmungsaktiv | breathable
- ▶ PE Boden | Groundsheet
- ▶ Fiberglass 11 mm
- ▶ SBS Marken Reißverschluss | SBS brand zipper
- ▶ Robuster Roll-down Packsack mit Kompressionsgurten | Durable roll down Packsack with compression straps
- ▶ Extra starke 5 mm Erdnägel | Durable, strong 5 mm pegs



## Außenzelt | Fly sheet

- ▶ Wettergeschützter Eingang | Weather protected entrance
- ▶ Vorbau mit Stauraum | Vestibule and storage
- ▶ Angenähter Zeltboden an der Innenzelt Front | Fixed vestibule floor to inner tent front
- ▶ Vorbau mit Faulstreifen | Vestibule incl. mudflap
- ▶ Klarsichtfolien-Fenster mit Abdeckung | Crystal clear window with cover
- ▶ Gaze Seiteneingang | Mesh side entry
- ▶ Extra große Ventilation im Schlafbereich mit Abspann Funktion | Oversized ventilation at sleeping area with guy out function
- ▶ 2 Dauerventilationen mit Abstandshalter | 2 permanent ventilations with distance holder
- ▶ Extra großer Abstand zwischen Außenzelt u. Innenzelt. Luftzirkulierung | Roomy space between fly sheet and inner tent. Air circulation
- ▶ Hochwertige, gut sichtbare neongrüne Abspannleinen | High grade, visible guy lines in neon green
- ▶ Gut sichtbarer neongrüner Bodenstreifen in der Dämmerung | Twilight visible neon green tape around bottom fly sheet
- ▶ Gestänge Markierung | Color marked poles

## Innenzelt | Inner tent

- ▶ 2 Vario Vent Control Eingänge | Vario Vent Control entries
- ▶ Wannboden | Tub floor
- ▶ Reißverschluss Trennwand | Zipped divider
- ▶ Organizer
- ▶ Innentaschen | Inner pockets
- ▶ Lampenhalter | Lamp holder



## PAROS 5

Art.-Nr./No. 11566 | EAN 4001690115667 | VPE/PU 1

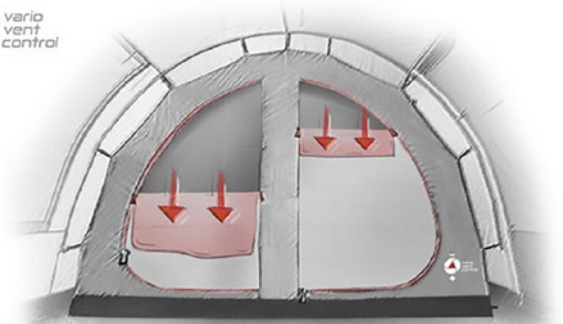
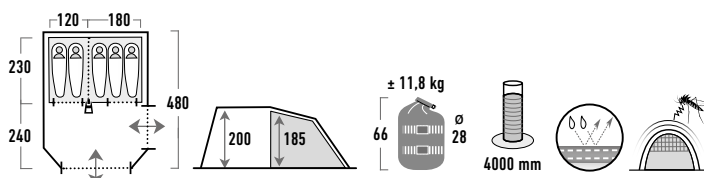



Video

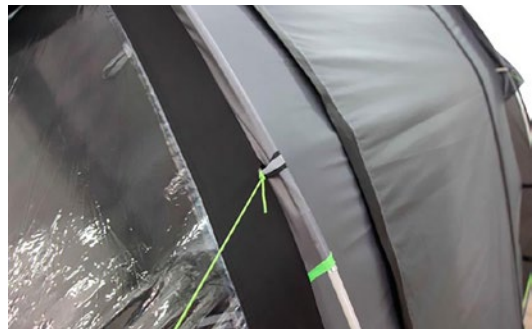

# TAURIS 4

## Tunnel Vis á Vis Zelt | Tunnel Vis á Vis tent

- ▶ Dunkelgrau-grün | Dark grey-green
- ▶ 190T Polyester PU
- ▶ Polyester atmungsaktiv | Breathable
- ▶ PE Boden | Groundsheet
- ▶ Fiberglass 11 mm · Stahl | Steel 16 mm
- ▶ SBS Marken Reißverschluss | SBS brand zipper
- ▶ Kompressionspacksack | Compression bag
- ▶ Extra starke 5 mm Erdnägel | Durable, strong 5 mm pegs

## Außenzelt | Fly sheet

- ▶ Wohnraum mit Sonnendach inkl. Aufstellstangen | Living area with canopy incl. up right poles
- ▶ Klarsichtfolien-Fenster mit Abdeckung | Crystal clear window with cover
- ▶ Herausnehmbarer Zeltboden | Detachable ground sheet
- ▶ Wohnraum mit Faulstreifen | Living area with mudflap
- ▶ 2 große Ventilationen im Schlafbereich mit Abspann Funktion | 2 oversized ventilation at sleeping area with guy out function
- ▶ Extra großer Abstand zwischen Außenzelt u. Innenzelt. Luftzirkulierung | Roomy space between fly sheet and inner tent. Air circulation
- ▶ Hochwertige, gut sichtbare neongrüne Abspannleinen | High grade, visible guy lines in neon green
- ▶ Gut sichtbarer neongrüner Bodenstreifen in der Dämmerung | Twilight visible neon green tape around bottom fly sheet
- ▶ Gestänge Markierung | Color marked poles

## Innenzelt | Inner tent

- ▶ 2 Innenzelte | 2 inner tents
- ▶ 2 Doppeltüren mit ganzflächigem Gaze-Eingängen | 2 Dual entries with full mesh doors
- ▶ Wannboden | Tub floor
- ▶ Organizer
- ▶ Innentaschen | Inner pockets
- ▶ Lampenhalter | Lamp holder



video



## TAURIS 4

Art.-Nr./No. **11560** | EAN **4001690115605** | VPE/PU 1

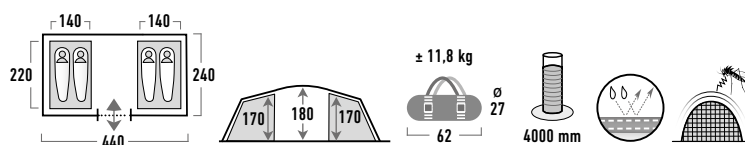

# TAURIS 6

## Tunnel Vis á Vis Zelt | Tunnel Vis á Vis tent

- ▶ Dunkelgrau-grün | Dark grey-green
- ▶ 190T Polyester PU
- ▶ Polyester atmungsaktiv | Breathable
- ▶ PE Boden | Groundsheet
- ▶ Fiberglass 11 mm · Stahl | Steel 16 mm
- ▶ SBS Marken Reißverschluss | SBS brand zipper
- ▶ Kompressionspacksack | Compression bag
- ▶ Extra starke 5 mm Erdnägel | Durable, strong 5 mm pegs

## Außenzelt | Fly sheet

- ▶ Wohnraum mit Sonnendach inkl. Aufstellstangen | Living area with canopy incl. up right poles
- ▶ 2 Eingänge | 2 entries
- ▶ Klarsichtfolien-Fenster mit Abdeckung | Crystal clear window with cover
- ▶ Gaze Fenster | Mesh window
- ▶ Herausnehmbarer Zeltboden | Detachable ground sheet
- ▶ Wohnraum mit Faulstreifen | Living area with mudflap
- ▶ 2 große Ventilationen im Schlafbereich mit Abspann Funktion | 2 oversized ventilation at sleeping area with guy out function
- ▶ Extra großer Abstand zwischen Außenzelt u. Innenzelt. Luftzirkulierung | Roomy space between fly sheet and inner tent. Air circulation
- ▶ Hochwertige, gut sichtbare neongrüne Abspannleinen | High grade, visible guy lines in neon green
- ▶ Gut sichtbarer neongrüner Bodenstreifen in der Dämmerung | Twilight visible neon green tape around bottom fly sheet
- ▶ Gestänge Markierung | Color marked poles

## Innenzelt | Inner tent

- ▶ 2 Innenzelte | 2 inner tents
- ▶ 2 Doppeltüren mit ganzflächigem Gaze-Eingängen | 2 Dual entries with full mesh doors
- ▶ Wannboden | Tub floor
- ▶ Organizer
- ▶ Innentaschen | Inner pockets
- ▶ Lampenhalter | Lamp holder



Video



## TAURIS 6

Art.-Nr./No. 11562 | EAN 4001690115629 | VPE/PU 1

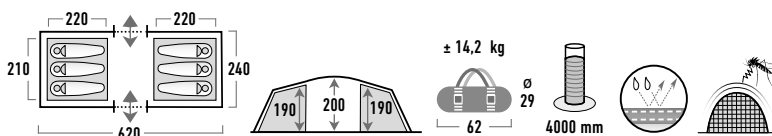

# Familien-Zelte

## Family Tents

### ZIELGRUPPE | TARGET GROUP

Familien Camping | Family camping

### EIGENSCHAFTEN | PERFORMANCE

Funktionelle Komfort-Campingzelte – großzügiger Wohnraum – Klarsichtfolien-Fenster mit Abdeckung – eingenähter Zeltboden – optimale Ventilationssysteme – flexible Innenzelte |  
Functional comfort camping tents – spacious living area – crystal clear window with cover – sewn in ground sheet – optimal ventilation system – flexible inner tents

### EINSATZBEREICH | APPLICATION

3 Jahreszeiten | 3 seasons

### AUSSTATTUNG | FEATURES

- ▶ Nahtversiegelt, wasserdicht | Seam sealed, waterproof
- ▶ Großer Wohnraum | Spacious living area
- ▶ Klarsichtfolien-Fenster mit Abdeckung | Crystal clear window with cover
- ▶ Gazefester | Mesh window
- ▶ Dauer- Ventilationssystem | Permanent ventilation system
- ▶ Vario Vent Control Eingang mit GazeFenster | Vario Vent Control entry with mesh window
- ▶ „SBS“ Reißverschluss, Querfestigkeit 600-800 N | „SBS“ zipper, lateral strength 600-800 N
- ▶ Abgedunkelte Schlafkabinen | Darkened inner tent
- ▶ Organizer

### PREMIUM AUSSTATTUNG | PREMIUM FEATURES

- ▶ Herausnehmbarer Zeltboden | Detachable ground sheet
- ▶ Eingenähter Zeltboden | Sewn-in ground sheet
- ▶ Seiteneingang mit Gazetür | Side entrance with mesh door
- ▶ Dual Flow Vent System
- ▶ RV.- Kabeleingang | Zipped cable point entry
- ▶ Innenzelt mit Reißverschluss-Trennwand | Inner tent with zipped divider
- ▶ Robuster, extra großer Kompressions-Packsack | Oversized, durable compression-pack sack



Climate Protection Dach |  
Climate protection roof

Strapazierfähiges  
Qualitäts-Polyester  
4000 mm wasserdicht |  
High quality durable  
polyester fabric  
4000 mm waterproof

Gazetüren |  
Mesh doors



Klarsichtfolien-Fenster mit Abdeckung |  
Crystal clear window with cover



DualFlow  
Vent System

Stehhöhe |  
Stand up height



Eingenähter Zeltboden |  
Sewn-in groundsheet



Abgedunkelte Schlafkabinen |  
Darkened inner tent

# SANTIAGO 5.0

## Kuppelzelt mit Vorbau | Dome tent with vestibule

- ▶ Hellgrau-dunkelgrau-grün |  
Light grey-dark grey-green
- ▶ 190T Polyester PU / Polyester Alu-Climate
- ▶ Polyester atmungsaktiv | Breathable
- ▶ PE Boden | Groundsheet
- ▶ Fiberglass 11 mm
- ▶ Stahl-Aufstellstangen |  
Steel upright poles 170 cm
- ▶ SBS Marken Reißverschluss |  
SBS brand zipper
- ▶ Kompressionspacksack |  
Compression bag
- ▶ Extra starke 5 mm Erdnägel  
und V Heringe |  
Durable, strong 5 mm pegs  
and V pegs

### Außenzelt | Fly sheet

- ▶ Eingenähter Zeltboden |  
Sewn-in ground sheet
- ▶ Doppel Tür mit ganzflächiger Gaze Tür |  
Dual entry with full mesh door
- ▶ 2 Klarsichtfolienfenster mit Abdeckung |  
2 crystal clear windows with cover
- ▶ 2 Gazefenster mit RV Abdeckklappen |  
2 mesh windows with zipped cover
- ▶ Dual Flow Vent System
- ▶ 2 Dauerventilationen mit Abstandhalter |  
2 permanent ventilations with distance holder
- ▶ RV Kabeleingang | Zipped cable point entry
- ▶ Verstellbare Spanngurtbänder |  
Adjustable tensioning straps
- ▶ Gestänge Markierung |  
Color marked poles



### Innenzelt | Inner tent

- ▶ Abgedunkeltes Innenzelt |  
Darkened inner tent
- ▶ Vario Vent Control Eingang |  
Vario Vent Control entry
- ▶ Organizer
- ▶ Innentaschen |  
Inner pockets
- ▶ Lampenhalter |  
Lamp holder



## SANTIAGO 5.0

Art.-Nr./No. **11802** | EAN **4001690118026** | VPE/PU 1

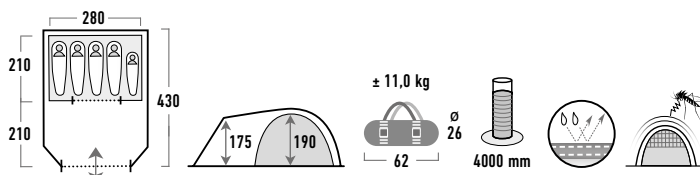



Video



Dual Flow  
Vent System



Individuell regulierbares Belüftungssystem | Individual adjustable ventilation system

# MERAN

## Tunnelzelt | Tunnel tent

- ▶ Hellgrau-dunkelgrau-grün |  
Light grey-dark grey-green
- ▶ 190T Polyester PU / Polyester Alu-Climate
- ▶ Polyester atmungsaktiv | Breathable
- ▶ PE Boden beidseitig beschichtet |  
PE groundsheet both side laminated
- ▶ Fiberglass 11 mm
- ▶ SBS Marken Reißverschluss |  
SBS brand zipper
- ▶ Robuster Rolldown Packsack mit  
Kompressionsgurten | Durable roll down  
packsac with compression straps
- ▶ Extra starke 5 mm Erdnägel und V Heringe |  
Durable, strong 5 mm pegs and V pegs

## Außenzelt | Fly sheet

- ▶ Eingenähter Zeltboden |  
Sewn-in ground sheet
- ▶ Doppel Tür mit ganzflächiger Gazetür |  
Dual entry with full mesh door
- ▶ Seiteneingang mit Gazetür | Side entry with mesh door
- ▶ Wohn- / Stauraum | Living / storage area
- ▶ Klarsichtfolienfenster mit Abdeckung |  
Crystal clear window with cover
- ▶ Dual Flow Vent System
- ▶ Dauerventilationen | Permanent ventilations
- ▶ RV Kabeleingang | Zipped cable point entry
- ▶ Verstellbare Spanngurtbänder |  
Adjustable tensioning straps



## MERAN 4.0

Art.-Nr./No. **11806** | EAN **4001690118064** | VPE/PU 1

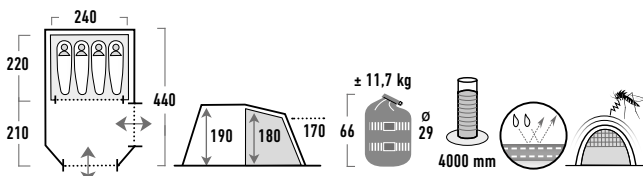

## MERAN 5.0

Art.-Nr./No. **11808** | EAN **4001690118088** | VPE/PU 1

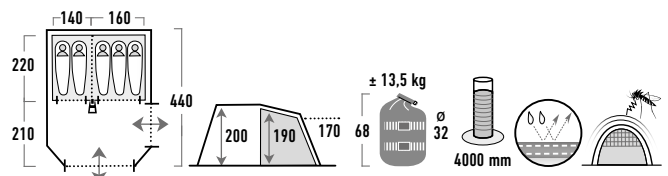

## Innenzelt | Inner tent

- ▶ Abgedunkeltes Innenzelt | Darkened inner tent
- ▶ Vario Vent Eingang mit Gazefenster (Meran 4.0) | Vario Vent entry with mesh window (Meran 4.0)
- ▶ 2 Vario Vent Control Eingänge mit Gazefenster (Meran 5.0) | 2 Vario Vent Control entries with mesh window (Meran 5.0)
- ▶ Reißverschluss Trennwand (Meran 5.0) | Zipped divider (Meran 5.0)
- ▶ Organizer
- ▶ Innentaschen | Inner pockets
- ▶ Lampenhalter | Lamp holder
- ▶ Positionsmarkierung passend zum Außenzelt erleichtern das Einhängen | Corresponding color code matching to outer tent for easy set up



Video



Individuell regulierbares Belüftungssystem | Individual adjustable ventilation system

# BRIXEN

## Familien Tunnelzelt | Family tunnel tent

- ▶ Hellgrau-dunkelgrau-grün |  
Light grey-dark grey-green
- ▶ 190T Polyester PU / Polyester Alu-Climate
- ▶ Polyester atmungsaktiv | Breathable
- ▶ PE Boden beidseitig beschichtet |  
PE groundsheet both side laminated
- ▶ Fiberglass 11 mm
- ▶ SBS Marken Reißverschluss |  
SBS brand zipper
- ▶ Robuster Rolldown Packsack mit  
Kompressionsgurten | Durable roll down  
packsac with compression straps
- ▶ Extra starke 5 mm Erdnägel und V Heringe |  
Durable, strong 5 mm pegs and V pegs

## Außenzelt | Fly sheet

- ▶ Eingenähter Zeltboden | Sewn-in ground sheet
- ▶ Eingang mit Gazefenster | Entry with mesh window
- ▶ Seiteneingang mit Gazetür | Side entry with mesh door
- ▶ Vordach | Porch
- ▶ Wohn- / Stauraum | Living / storage area
- ▶ Klarsichtfolienfenster mit Abdeckung | Crystal clear window with cover
- ▶ Dual Flow Vent System
- ▶ Dauerventilationen | Permanent ventilations
- ▶ RV Kabeleingang | Zipped cable point entry
- ▶ Verstellbare Spanngurtbänder | Adjustable tensioning straps



## BRIXEN 4.0

Art.-Nr./No. **11815** | EAN **4001690118156** | VPE/PU **1**

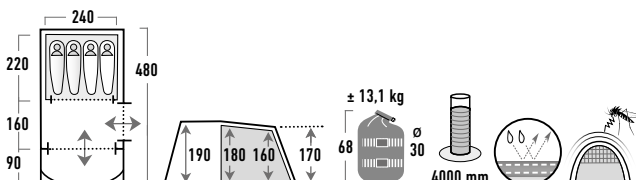

## BRIXEN 5.0

Art.-Nr./No. **11816** | EAN **4001690118163** | VPE/PU **1**

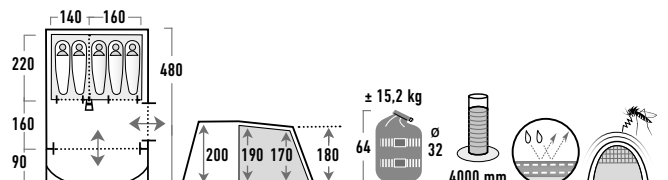

## Innenzelt | Inner tent

- ▶ Abgedunkeltes Innenzelt | Darkened inner tent
- ▶ Vario Vent Eingang mit Gazefenster (Brixen 4.0) | Vario Vent entry with mesh window (Brixen 4.0)
- ▶ 2 Vario Vent Control Eingänge mit Gazefenster (Brixen 5.0) | 2 Vario Vent Control entries with mesh window (Brixen 5.0)
- ▶ Reißverschluss Trennwand (Brixen 5.0) | Zipped divider (Brixen 5.0)
- ▶ Organizer
- ▶ Innentaschen | Inner pockets
- ▶ Lampenhalter | Lamp holder
- ▶ Positionsmarkierung passend zum Außenzelt erleichtern das Einhängen | Corresponding color code matching to outer tent for easy set up



Video



Individuell regulierbares Belüftungssystem | Individual adjustable ventilation system

## Familien Tunnelzelt | Family tunnel tent

- ▶ Hellgrau-dunkelgrau-grün |  
Light grey-dark grey-green
- ▶ 190T Polyester PU / Polyester Alu-Climate
- ▶ Polyester atmungsaktiv | Breathable
- ▶ PE Boden beidseitig beschichtet |  
PE groundsheet both side laminated
- ▶ Fiberglass 11 mm
- ▶ SBS Marken Reißverschluss | SBS brand zipper
- ▶ Robuster Roll-down Packsack mit  
Kompressionsgurten | Durable roll down  
packsac with compression straps
- ▶ Extra starke 5 mm Erdnägel und V Heringe |  
Durable, strong 5 mm pegs and V pegs

## Außenzelt | Fly sheet

- ▶ Eingenähter Zeltboden | Sewn-in ground sheet
- ▶ Teilbare Veranda Front komplett zu öffnen | Divisible roll away veranda front
- ▶ Seiteneingang mit Gazetür | Side entry with mesh door
- ▶ Vordach mit Klarsichtfolien-Fenster | Porch with crystal clear window
- ▶ Großer Wohnraum | Spacious living area
- ▶ Klarsichtfolienfenster mit Abdeckung | Crystal clear window with cover
- ▶ Gazefenster mit RV Abdeckklappen | Mesh window with zipped cover
- ▶ Dual Flow Vent System
- ▶ RV Kabeleingang | Zipped cable point entry
- ▶ Verstellbare Spanngurtbänder | Adjustable tensioning straps



## GARDA 4.0

Art.-Nr./No. **11821** | EAN **4001690118217** | VPE/PU 1

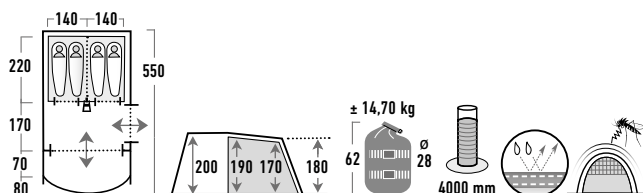

## GARDA 5.0

Art.-Nr./No. **11823** | EAN **4001690118231** | VPE/PU 1

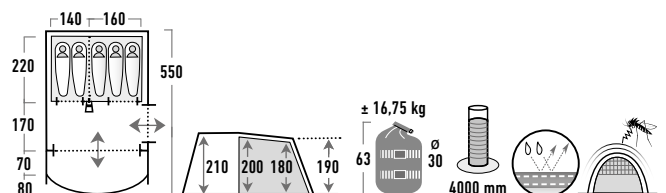



## Innenzelt | Inner tent

- ▶ Abgedunkeltes Innenzelt | Darkened inner tent
- ▶ 2 Vario Vent Control Eingänge mit Gazefenster | 2 Vario Vent Control entries with mesh window
- ▶ Reißverschluss Trennwand | Zipped divider
- ▶ Organizer
- ▶ Innentaschen | Inner pockets
- ▶ Lampenhalter | Lamp holder
- ▶ Positionsmarkierung passend zum Außenzelt erleichtert das Einhängen | Corresponding color code matching to outer tent for easy set up



Video



Individuell regulierbares Belüftungssystem | Individual adjustable ventilation system

## BOZEN

Familien Tunnelzelt |  
Family tunnel tent

- ▶ Hellgrau-dunkelgrau-grün |  
Light grey-dark grey-green
- ▶ 190T Polyester PU / Polyester Alu-Climate
- ▶ Polyester atmungsaktiv | Breathable
- ▶ PE Boden beidseitig beschichtet |  
PE groundsheet both side laminated
- ▶ Fiberglass 11 mm
- ▶ SBS Marken Reißverschluss |  
SBS brand zipper
- ▶ Robuster Rolldown Packsack mit  
Kompressionsgurten | Durable roll down  
packsac with compression straps
- ▶ Extra starke 5 mm Erdnägel und V Heringe |  
Durable, strong 5 mm pegs and V pegs

## Außenzelt | Fly sheet

- ▶ Eingenähter Zeltboden | Sewn-in ground sheet
- ▶ Doppel Tür mit ganzflächiger Gaze Tür | Dual entry with full mesh door
- ▶ Seiteneingang mit Gazetür | Side entry with mesh door
- ▶ Großer Wohnraum | Spacious living area
- ▶ Klarsichtfolienfenster mit Abdeckung | Crystal clear window with cover
- ▶ Dual Flow Vent System
- ▶ Dauerventilationen | Permanent ventilations
- ▶ RV Kabeleingang | Zipped cable point entry
- ▶ Verstellbare Spanngurtbänder | Adjustable tensioning straps



## BOZEN 5.0

Art.-Nr./No. 11836 | EAN 4001690118361 | VPE/PU 1

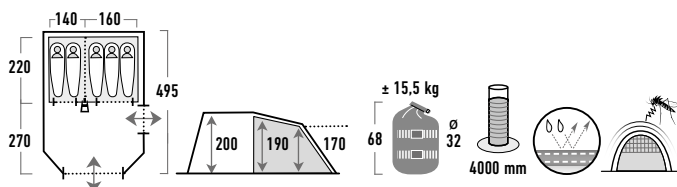

## BOZEN 6.0

Art.-Nr./No. 11837 | EAN 4001690118378 | VPE/PU 1

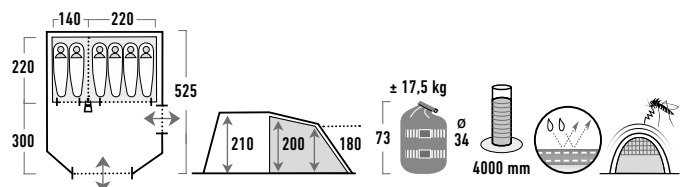

## Innenzelt | Inner tent

- ▶ Abgedunkeltes Innenzelt | Darkened inner tent
- ▶ 2 Vario Vent Control Eingänge mit Gazefenster | 2 Vario Vent Control entries with mesh window
- ▶ Reißverschluss Trennwand | Zipped divider
- ▶ Organizer
- ▶ Innentaschen | Inner pockets
- ▶ Lampenhalter | Lamp holder
- ▶ Positionsmarkierung passend zum Außenzelt erleichtern das Einhängen | Corresponding color code matching to outer tent for easy set up



Video



**Dual Flow**  
Vent System



Individuell regulierbares Belüftungssystem | Individual adjustable ventilation system

# COMO

## Vis á Vis Zelt mit Wohnkuppel | Vis á Vis tent with dome shaped living area

- ▶ Dunkelgrau-grün | Dark grey-green
- ▶ 190T Polyester PU
- ▶ Polyester atmungsaktiv | Breathable
- ▶ PE Boden | Groundsheet
- ▶ Fiberglass
- ▶ SBS Marken Reißverschluss |  
SBS brand zipper
- ▶ Reißverschluss Tragetasche |  
Zipped carry bag
- ▶ Extra starke 5 mm Erdnägel |  
Durable, strong 5 mm pegs



## Außenzelt | Fly sheet

- ▶ Vergrößerter Schlafbereich durch neue Gestängeführung |  
Extended sleeping area by new pole location
- ▶ Wohnkuppel |  
Dome living area
- ▶ Klarsichtfolien-Fenster mit Abdeckung |  
Crystal clear window with cover
- ▶ Gazefenster mit Abdeckklappe |  
Mesh window with cover
- ▶ Hochentlüftung |  
High level ventilation
- ▶ 2 Dauerventilationen |  
2 permanent ventilations
- ▶ Extra großer Abstand zwischen Außenzelt u.  
Innenzelt. Luftzirkulierung |  
Roomy space between fly sheet and  
inner tent. Air circulation
- ▶ Gestänge Markierung |  
Color marked poles



## COMO 4.0

Art.-Nr./No. 10260 | EAN 4001690102605 | VPE/PU 1

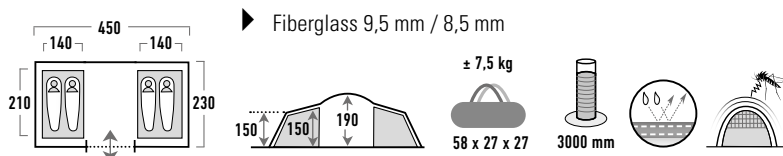

## Innenzelt | Inner tent

- ▶ 2 Abgedunkelte Innenzelte | 2 darkened inner tents
- ▶ 2 Vario Vent Control Eingänge | 2 Vario Vent Control entries
- ▶ Wannenboden | Tub floor
- ▶ Organizer
- ▶ Innentaschen | Inner pockets
- ▶ Lampenhalter | Lamp holder
- ▶ Positionsmarkierung passend zum Außenzelt erleichtert das Einhängen | Corresponding color code matching to outer tent for easy set up



Video



## COMO 6.0

Art.-Nr./No. **10263** | EAN **4001690102636** | VPE/PU 1

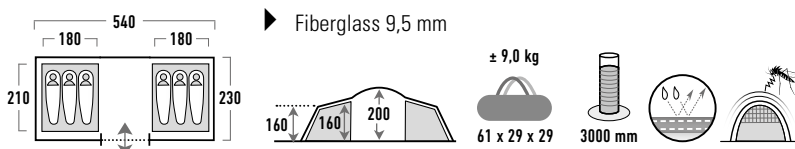

# ANGONA

## Familien Tunnelzelt | Family tunnel tent

- ▶ Hellgrau-dunkelgrau-grün |  
Light grey-dark grey-green
- ▶ 190T Polyester PU / Polyester Alu-Climate
- ▶ Polyester atmungsaktiv | Breathable
- ▶ PE Boden | Groundsheet
- ▶ Fiberglass
- ▶ SBS Marken Reißverschluss |  
SBS brand zipper
- ▶ Reißverschluss Tragetasche |  
Zipped carry bag
- ▶ Extra starke 5 mm Erdnägel |  
Durable, strong 5 mm pegs



## Außenzelt | Fly sheet

- ▶ Wettergeschützter Eingang |  
Weather protected entrance
- ▶ Vorbau mit Wohnfläche u. Stauraum |  
Vestibule with living area and storage
- ▶ Faulstreifen im Wohnbereich |  
Mudflap at living area
- ▶ Herausnehmbarer Zeltboden |  
Detachable ground sheet
- ▶ Seiteneingang mit Reißverschluss Einfassband nahtversiegelt |  
Side entry with zipper fabric tape seamsealed
- ▶ Klarsichtfolienfenster mit Abdeckung |  
Crystal clear window with cover
- ▶ Gazefenster mit Abdeckklappe |  
Mesh window with cover
- ▶ Extra große Ventilation im Schlafbereich mit Abspann Funktion |  
Oversized ventilation at sleeping area with guy out function
- ▶ 2 Dauerventilationen mit Abstandshalter |  
2 permanent ventilations with distance holder
- ▶ Extra großer Abstand zwischen Außenzelt u. Innenzelt. Luftzirkulierung |  
Roomy space between fly sheet and inner tent. Air circulation
- ▶ Gestänge Markierung |  
Color marked poles



## ANGONA 4.0

Art.-Nr./No. 10244 | EAN 4001690102445 | VPE/PU 1

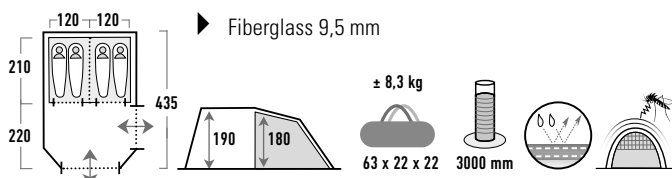

## Innenzelt | Inner tent

- ▶ Abgedunkeltes Innenzelt | Darkened inner tent
- ▶ 2 Vario Vent Control Eingänge | 2 Vario Vent Control entries
- ▶ Wannenboden | Tub floor
- ▶ Herausnehmbare Trennwand | Detachable divider
- ▶ Organizer
- ▶ Innentaschen | Inner pockets
- ▶ Lampenhalter | Lamp holder
- ▶ Positionsmarkierung passend zum Außenzelt erleichtert das Einhängen | Corresponding color code matching to outer tent for easy set up



Video



## ANCONA 5.0

Art.-Nr./No. **10249** | EAN **4001690102490** | VPE/PU **1**

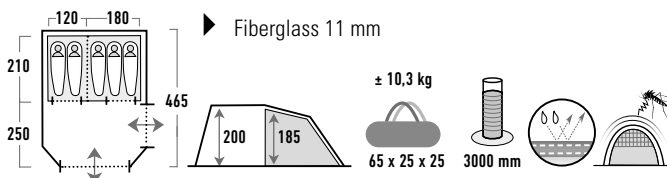

# Leichtgewicht Active Serie

## Lightweight Active Series

### ZIELGRUPPE | TARGET GROUP

Trekking – Wandertouren – Rucksackreisen –  
Fahrrad/Motorradtouren – Camping |  
Trekking – Hiking – Backpacking – Motor cycle/bike touring – Camping

### EIGENSCHAFTEN | PERFORMANCE

Leichtgewicht – kleines Packmaß – windstabil,  
schneller und leichter Aufbau |  
Lightweight – small pack size – wind stable – quick and easy set up

### EINSATZBEREICH | APPLICATION

3 Jahreszeiten | 3 seasons

### AUSSTATTUNG | FEATURES

- ▶ Aluminium Gestänge 7001 T6 |  
Aluminium poles 7001 T6 optional Fiberglas
- ▶ Aluminium Erdnägel | Peg
- ▶ Nahtversiegelt, wasserdicht | Seam sealed, waterproof
- ▶ Außenzelt - Innenzelt gekoppelt für schnellen Aufbau |  
Outer tent - inner tent connected for quick set up
- ▶ Innenzelt extra lang 230 cm | Inner tent extra long 230 cm
- ▶ Doppeltür mit ganzflächigem Gaze- Eingang |  
Dual mesh door
- ▶ Dauer- Ventilationssystem | Permanent ventilation system
- ▶ „SBS“ Reißverschluss, Querfestigkeit 600-800 N |  
SBS zipper, lateral strength 600-800 N
- ▶ Reißverschluss- Abdeckklappen | Zipper cover
- ▶ Quick Fix Alu Dreilochspanner |  
Quick Fix Alu triangular runner

### PREMIUM AUSSTATTUNG | PREMIUM FEATURES

- ▶ Zeltboden und Faulstreifen im Vorbau |  
Ground sheet with mudflap in the porch area
- ▶ Klarsichtfolienfenster |  
Crystal clear window
- ▶ Gazefenster | Mesh window
- ▶ Advanced Low Vent System
- ▶ Easy stow away Tür-System |  
Easy stow away door system

Easy Stow Away Tür-System |  
Easy stow away door system





Strapazierfähiges Qualitäts-Polyester 3000 mm, wasserdicht |  
Durable quality-polyester 3000 mm, waterproof

Quick Fix Alu Dreilochspanner |  
Quick Fix alu triangular runner



Zeltboden 3000 mm wasserdicht |  
Ground sheet 3000 mm waterproof

Faulstreifen | Mudflap



Doppeltür mit ganzflächigem Gaze-Eingang |  
Dual door with full mesh door



Hochentlüftung | Top ventilation



Gaze-Fenster | Mesh window



**advanced**  
**low vent**

# SISKIN 2.0 LW

**Super Leichtgewicht Einbogenzelt mit Aluminium-Gestänge**  
**Super lightweight one pole tent with aluminium poles**



Aluminium Gestänge 7001 T6 |  
Aluminium poles 7001 T6



Sehr stabil |  
High stability



Gewicht |  
Weight: 1,6 kg



Langlebig |  
Durable



Kleines Packmaß |  
Small pack size



Aluminium Erdnägel |  
Aluminium pegs



Video

- ▶ Pesto-rot | Pesto-red
- ▶ 190T Polyester PU
- ▶ 190T Polyester Boden | Ground sheet
- ▶ Aluminium Gestänge 7001 T6 7,9 mm | Aluminium poles
- ▶ SBS Marken Reißverschluss | SBS brand zipper
- ▶ Aluminium Erdnägel | Peg
- ▶ Reißverschluss Tragetasche | Zipped carry bag

## Außenzelt | Fly sheet

- ▶ Einfachdach mit 5 Dauerventilationen | Single skin with 5 permanent ventilations
- ▶ 1 extra große permanente Dachbelüftung mit Abstandshalter | 1 extra large permanent top ventilation with distance bar
- ▶ 2 Dauerventilationen mit Abstandshalter | 2 permanent ventilations with distance holder
- ▶ 2 Bodenlüfter | 2 low vents
- ▶ Eingang mit Abspannfunktion für zusätzliche Belüftung | Door with guy out function for additional ventilation
- ▶ 2 Abspann-Dreiecke mit Gurtband u. Abstandshalter | 2 triangular flaps with webbing straps and distance bar
- ▶ 90° Bodenwanne mit Aufstellstäben | 90° tub floor with supporting poles
- ▶ Doppeltür mit ganzflächigem Gaze-Eingang | Dual entry with full mesh door
- ▶ Gut sichtbarer roter Bodenstreifen in der Dämmerung | Twilight visible red tape around bottom fly sheet
- ▶ Innentaschen | Inner pockets
- ▶ Lampenhalter | Lamp holder

**EXTRA  
LIGHTWEIGHT**



**Extra große  
Belüftungen**  
Extra large  
ventilations

- ▶ Eingang mit Abspannfunktion für zusätzliche Belüftung | Door with guy out function for additional ventilation

## SISKIN 2.0 LW

Art.-Nr./No. **10330** | EAN **4001690103305** | VPE/PU 6



# SISKIN 2.0

Super Leichtgewicht Einbogenzelt |  
Super lightweight one pole tent



Video

TENTS

ZELTE

- ▶ Pesto-rot | Pesto-red
- ▶ 190T Polyester PU
- ▶ 190T Polyester Boden | Ground sheet
- ▶ Fiberglass 7,9 mm
- ▶ SBS Marken Reißverschluss | SBS brand zipper
- ▶ Reißverschluss Tragetasche | Zipped carry bag

## Außenzelt | Fly sheet

- ▶ Einfachdach mit 5 Dauerventilationen | Single skin with 5 permanent ventilations
- ▶ 1 extra große permanente Dachbelüftung mit Abstandshalter | 1 extra large permanent top ventilation with distance bar
- ▶ 2 Dauerventilationen mit Abstandshalter | 2 permanent ventilations with distance holder
- ▶ 2 Bodenlüfter | 2 low vents
- ▶ Eingang mit Abspannfunktion für zusätzliche Belüftung | Door with guy out function for additional ventilation
- ▶ 2 Abspann-Dreiecke mit Gurtband u. Abstandshalter | 2 triangular flaps with webbing straps and distance bar
- ▶ 90° Bodenwanne mit Aufstellstäben | 90° tub floor with supporting poles
- ▶ Doppeltür mit ganzflächigem Gaze-Eingang | Dual entry with full mesh door
- ▶ Gut sichtbarer roter Bodenstreifen in der Dämmerung | Twilight visible red tape around bottom fly sheet
- ▶ Innentaschen | Inner pockets
- ▶ Lampenhalter | Lamp holder



Extra große  
Belüftungen  
Extra large  
ventilations



## SISKIN 2.0

Art.-Nr./No. 10184 | EAN 4001690101844 | VPE/PU 6



- ▶ Eingang mit Abspannfunktion für zusätzliche Belüftung | Door with guy out function for additional ventilation

# SPARROW LW

**Leichtgewicht Tunnelzelt  
mit Aluminium-Gestänge |  
Lightweight tunnel tent  
with aluminium poles**



Aluminium Gestänge 7001 T6 |  
Aluminium poles 7001 T6



Sehr stabil |  
High stability



Gewicht |  
Weight: 2,2 kg



Langlebig |  
Durable



Kleines Packmaß |  
Small pack size



Aluminium Erdnägel |  
Aluminium pegs



Video

- ▶ Pesto-rot | Pesto-red
- ▶ 190T Polyester PU
- ▶ Polyester atmungsaktiv | Breathable
- ▶ 190T Polyester PU Boden | Groundsheet
- ▶ Aluminium Gestänge 7001 T6 7,9 mm | Aluminium poles
- ▶ SBS Marken Reißverschluss | SBS brand zipper
- ▶ Aluminium Erdnägel | Peg
- ▶ Packsack mit extra weiter Öffnung | Pack sack with wide mouth opening

## Außenzelt | Fly sheet

- ▶ 3 Dauerventilationen mit Abstandshalter | 3 permanent ventilations with distance holder
- ▶ Extra breiter Seiteneingang | Extra wide side entrance
- ▶ Extra großer Abstand zwischen Außenzelt u. Innenzelt. Luftzirkulierung | Roomy space between fly sheet and inner tent. Air circulation
- ▶ Türe kann als Zeltboden benutzt werden | Door can be used as ground sheet
- ▶ Gut sichtbarer roter Bodenstreifen in der Dämmerung | Twilight visible red tape around bottom fly sheet
- ▶ Gestänge Markierung | Color marked poles

## Innenzelt | Inner tent

- ▶ Innenzelt vormontiert | Pre-mounted inner tent
- ▶ Extra lang 240 cm | Extra long 240 cm
- ▶ Doppeltür mit ganzflächigem Gaze-Eingang | Dual entry with full mesh door
- ▶ Trocken Stauraum | Dry storage
- ▶ Wannboden | Tub floor
- ▶ Innentaschen | Inner pockets
- ▶ Lampenhalter | Lamp holder

**EXTRA  
LIGHTWEIGHT**



## SPARROW LW

Art.-Nr./No. **10187** | EAN **4001690101875** | VPE/PU 4



# SPARROW

Leichtgewicht Tunnelzelt |  
Lightweight tunnel tent



Video

TENTS

ZELTE

- ▶ Pesto-rot | Pesto-red
- ▶ 190T Polyester PU
- ▶ Polyester atmungsaktiv | Breathable
- ▶ 190T Polyester PU Boden | Groundsheet
- ▶ Fiberglass 7,9 mm
- ▶ SBS Marken Reißverschluss | SBS brand zipper
- ▶ Packsack mit extra weiter Öffnung | Pack sack with wide mouth opening

## Außenzelt | Fly sheet

- ▶ 3 Dauerventilationen mit Abstandshalter | 3 permanent ventilations with distance holder
- ▶ Extra breiter Seiteneingang | Extra wide side entrance
- ▶ Extra großer Abstand zwischen Außenzelt u. Innenzelt. Luftzirkulierung | Roomy space between fly sheet and inner tent. Air circulation
- ▶ Türe kann als Zeltboden benutzt werden | Door can be used as ground sheet
- ▶ Gut sichtbarer roter Bodenstreifen in der Dämmerung | Twilight visible red tape around bottom fly sheet
- ▶ Gestänge Markierung | Color marked poles

## Innenzelt | Inner tent

- ▶ Innenzelt vormontiert | Pre-mounted inner tent
- ▶ Extra lang 240 cm | Extra long 240 cm
- ▶ Doppeltür mit ganzflächigem Gaze-Eingang | Dual entry with full mesh door
- ▶ Trocken Stauraum | Dry storage
- ▶ Wannenboden | Tub floor
- ▶ Innentaschen | Inner pockets
- ▶ Lampenhalter | Lamp holder



## SPARROW

Art.-Nr./No. **10186** | EAN **4001690101868** | VPE/PU 4

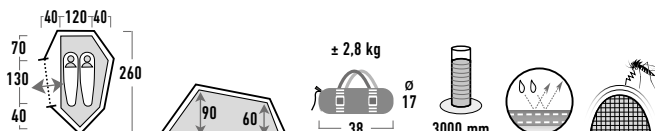

# KITE 2 LW

**Leichtgewicht Tunnelzelt  
mit Aluminium-Gestänge**  
Lightweight tunnel tent  
with aluminium poles



Aluminium Gestänge 7001 T6 |  
Aluminium poles 7001 T6



Sehr stabil |  
High stability



Gewicht |  
Weight: 2,8 kg



Langlebig |  
Durable



Kleines Packmaß |  
Small pack size



Aluminium Erdnägel |  
Aluminium pegs



Video

- ▶ Pesto-rot | Pesto-red
- ▶ 190T Polyester PU
- ▶ Polyester atmungsaktiv | Breathable
- ▶ 190T Polyester PU Boden | Groundsheet
- ▶ Aluminium Gestänge 7001 T6 7,9 mm |  
Aluminium poles
- ▶ SBS Marken Reißverschluss |  
SBS brand zipper
- ▶ Aluminium Erdnägel | Peg
- ▶ Reißverschluss Tragetasche |  
Zipped carry bag

## Außenzelt | Fly sheet

- ▶ Wettergeschützter Eingang | Weather protected entrance
- ▶ Angenähter Zeltboden an der Innenzelfront |  
Fixed vestibule floor to inner tent front
- ▶ Vorbau mit Faulstreifen | Vestibule incl. mudflap
- ▶ Extra großer Abstand zwischen Außenzelt u. Innenzelt. Luftzirkulierung |  
Roomy space between fly sheet and inner tent. Air circulation
- ▶ 2 Dauerventilationen mit Abstandshalter |  
2 permanent ventilations with distance holder
- ▶ Lichtquellenfenster | Crystal clear window
- ▶ Gut sichtbarer roter Bodenstreifen in der Dämmerung |  
Twilight visible red tape around bottom fly sheet
- ▶ Gestänge Markierung | Color marked poles

## Innenzelt | Inner tent

- ▶ Innenzelt vormontiert | Pre-mounted inner tent
- ▶ Extra lang 230 cm | Extra long 230 cm
- ▶ Wannboden | Tub floor
- ▶ Doppeltür mit ganzflächigem Gaze-Eingang | Dual entry with full mesh door
- ▶ Easy stow away Türsystem | Easy stow away door system
- ▶ Innentaschen | Inner pockets
- ▶ Lampenhalter | Lamp holder



## KITE 2 LW

Art.-Nr./No. 10343 | EAN 4001690103435 | VPE/PU 4

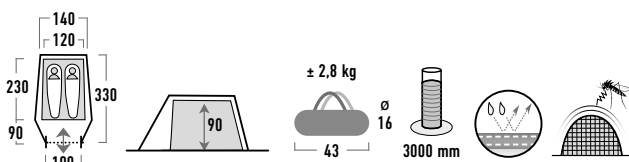

# KITE 2

Leichtgewicht Tunnelzelt |  
Lightweight tunnel tent



Video

TENTS

ZELTE

- ▶ Pesto-rot | Pesto-red
- ▶ 190T Polyester PU
- ▶ Polyester atmungsaktiv | breathable
- ▶ 190T Polyester Boden | Ground sheet
- ▶ Fiberglass 7,9 mm
- ▶ SBS Marken Reißverschluss | SBS brand zipper
- ▶ Reißverschluss Tragetasche | Zipped carry bag

## Außenzelt | Fly sheet

- ▶ Wettergeschützter Eingang | Weather protected entrance
- ▶ Angenähter Zeltboden an der Innenzelfront | Fixed vestibule floor to inner tent front
- ▶ Vorbau mit Faulstreifen | Vestibule incl. mudflap
- ▶ Extra großer Abstand zwischen Außenzelt u. Innenzelt. Luftzirkulierung | Roomy space between fly sheet and inner tent. Air circulation
- ▶ 2 Dauerventilationen mit Abstandshalter | 2 permanent ventilations with distance holder
- ▶ Lichtquellenfenster | Crystal clear window
- ▶ Gut sichtbarer roter Bodenstreifen in der Dämmerung | Twilight visible red tape around bottom fly sheet
- ▶ Gestänge Markierung | Color marked poles

## Innenzelt | Inner tent

- ▶ Innenzelt vormontiert | Pre-mounted inner tent
- ▶ Extra lang 230 cm | Extra long 230 cm
- ▶ Wannboden | Tub floor
- ▶ Doppeltür mit ganzflächigem Gaze-Eingang | Dual entry with full mesh door
- ▶ Easy stow away Türsystem | Easy stow away door system
- ▶ Innentaschen | Inner pockets
- ▶ Lampenhalter | Lamp holder







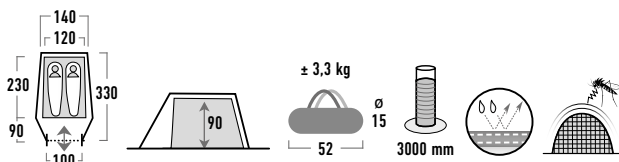

## KITE 2

Art.-Nr./No. **10188** | EAN **4001690101882** | VPE/PU 4



# KITE 3 LW

**Leichtgewicht Tunnelzelt  
mit Aluminium-Gestänge |  
Lightweight tunnel tent  
with aluminium poles**

-  Aluminium Gestänge 7001 T6 | Aluminium poles 7001 T6
-  Sehr stabil | High stability
-  Gewicht | Weight: 3,4 kg
-  Langlebig | Durable
-  Kleines Packmaß | Small pack size
-  Aluminium Erdnägel | Aluminium pegs



Video

- ▶ Pesto-rot | Pesto-red
- ▶ 190T Polyester PU
- ▶ Polyester atmungsaktiv | Breathable
- ▶ 190T Polyester PU Boden | Groundsheet
- ▶ Aluminium Gestänge 7001 T6 7,9 mm | Aluminium poles
- ▶ SBS Marken Reißverschluss | SBS brand zipper
- ▶ Aluminium Erdnägel | Peg
- ▶ Reißverschluss Tragetasche | Zipped carry bag

## Außenzelt | Fly sheet

- ▶ Wettergeschützter Eingang | Weather protected entrance
- ▶ Angenähter Zeltboden an der Innenzelfront | Fixed vestibule floor to inner tent front
- ▶ Vorbau mit Faulstreifen | Vestibule incl. mudflap
- ▶ Extra großer Abstand zwischen Außenzelt u. Innenzelt. Luftzirkulierung | Roomy space between fly sheet and inner tent. Air circulation
- ▶ 2 Dauerventilationen mit Abstandshalter | 2 permanent ventilations with distance holder
- ▶ Lichtquellenfenster | Crystal clear window
- ▶ Gut sichtbarer roter Bodenstreifen in der Dämmerung | Twilight visible red tape around bottom fly sheet
- ▶ Gestänge Markierung | Color marked poles

## Innenzelt | Inner tent

- ▶ Innenzelt vormontiert | Pre-mounted inner tent
- ▶ Extra lang 230 cm | Extra long 230 cm
- ▶ Wannboden | Tub floor
- ▶ Doppeltür mit ganzflächigem Gaze-Eingang | Dual entry with full mesh door
- ▶ Easy stow away Türsystem | Easy stow away door system
- ▶ Innentaschen | Inner pockets
- ▶ Lampenhalter | Lamp holder

**EXTRA  
LIGHTWEIGHT**

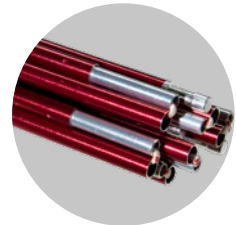

## KITE 3 LW

Art.-Nr./No. **10344** | EAN **4001690103442** | VPE/PU 4

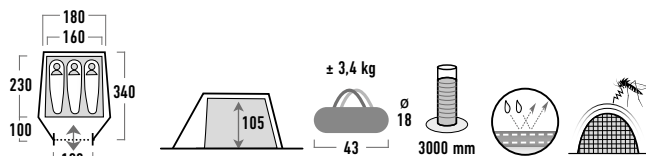



# KITE 3

Leichtgewicht Tunnelzelt |  
Lightweight tunnel tent



Video

TENTS

ZELTE

- ▶ Pesto-rot | Pesto-red
- ▶ 190T Polyester PU
- ▶ Polyester atmungsaktiv | Breathable
- ▶ 190T Polyester Boden | Ground sheet
- ▶ Fiberglass 7,9 mm
- ▶ SBS Marken Reißverschluss | SBS brand zipper
- ▶ Reißverschluss Tragetasche | Zipped carry bag

## Außenzelt | Fly sheet

- ▶ Wettergeschützter Eingang | Weather protected entrance
- ▶ Angenähter Zeltboden an der Innenzelfront | Fixed vestibule floor to inner tent front
- ▶ Vorbau mit Faulstreifen | Vestibule incl. mudflap
- ▶ Extra großer Abstand zwischen Außenzelt u. Innenzelt. Luftzirkulierung | Roomy space between fly sheet and inner tent. Air circulation
- ▶ 2 Dauerventilationen mit Abstandshalter | 2 permanent ventilations with distance holder
- ▶ Lichtquellenfenster | Crystal clear window
- ▶ Gut sichtbarer roter Bodenstreifen in der Dämmerung | Twilight visible red tape around bottom fly sheet
- ▶ Gestänge Markierung | Color marked poles

## Innenzelt | Inner tent

- ▶ Innenzelt vormontiert | Pre-mounted inner tent
- ▶ Extra lang 230 cm | Extra long 230 cm
- ▶ Wannboden | Tub floor
- ▶ Doppeltür mit ganzflächigem Gaze-Eingang | Dual entry with full mesh door
- ▶ Easy stow away Türsystem | Easy stow away door system
- ▶ Innentaschen | Inner pockets
- ▶ Lampenhalter | Lamp holder



# KITE 3

Art.-Nr./No. **10189** | EAN **4001690101899** | VPE/PU 4

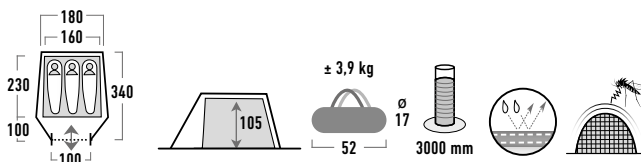

# FALCON 3 LW

**Leichtgewicht-Tunnelzelt mit Vorbau mit Aluminium-Gestänge | Lightweight tunnel tent with vestibule with aluminium poles**



Aluminium Gestänge 7001 T6 | Aluminium poles 7001 T6



Sehr stabil | High stability



Gewicht | Weight: 4,1 kg



Langlebig | Durable



Kleines Packmaß | Small pack size



Aluminium Erdnägel | Aluminium pegs



Video

- ▶ Pesto-rot | Pesto-red
- ▶ 190T Polyester PU, 3000 mm
- ▶ Polyester atmungsaktiv | Breathable
- ▶ 190T Polyester PU, 3000 mm Boden | Groundsheet
- ▶ Aluminium Gestänge 7001 T6 8,5 mm | Aluminium poles
- ▶ SBS Marken Reißverschluss | SBS brand zipper
- ▶ Aluminium Erdnägel | Peg
- ▶ Reißverschluß Packsack | Zipped pack sack

## Außenzelt | Fly sheet

- ▶ Wettergeschützter Eingang | Weather protected entrance
- ▶ Reißverschluss Abdeckklappe mit Regenrinne | Zipper flap with rain gusset
- ▶ XL Vorbau mit Stauraum | XL vestibule with storage space
- ▶ Angenähter Zeltboden an der Innenzelt front | Fixed vestibule floor on inner tent front
- ▶ Vorbau mit Faulstreifen | Vestibule with mudflap
- ▶ 2 Eingänge | 2 entries
- ▶ 2 Dauerventilationen | 2 permanent ventilations
- ▶ Extra großer Abstand zwischen Außenzelt u. Innenzelt. Luftzirkulierung | Roomy space between fly sheet and inner tent. Air circulation
- ▶ Gaze-Fenster mit Reißverschluss Abdeckklappe von innen zu bedienen | Mesh window with zipped cover to operate from inside
- ▶ Gut sichtbarer roter Bodenstreifen in der Dämmerung | Twilight visible red tape around bottom fly sheet
- ▶ Gestänge Markierung | Color marked poles

## Innenzelt | Inner tent

- ▶ Innenzelt vormontiert | Pre-mounted inner tent
- ▶ Extra lang 230 cm | Extra long 230 cm
- ▶ Doppeltür mit ganzflächigem Gaze-Eingang | Dual entry with full mesh door
- ▶ Easy stow away Tür-System | Easy stow away door system
- ▶ Wannenboden | Tub floor
- ▶ Innentaschen | Inner pockets
- ▶ Lampenhalter | Lamp holder

EXTRA  
LIGHTWEIGHT



## FALCON 3 LW

Art.-Nr./No. 10331 | EAN 4001690103312 | VPE/PU 4

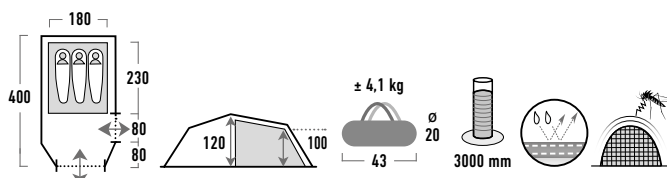

# FALCON 3

Tunnelzelt mit Vorbau |  
Tunnel tent with vestibule



Video

TENTS

ZELTE

- ▶ Pesto-rot | Pesto-red
- ▶ 190T Polyester PU, 3000 mm
- ▶ Polyester atmungsaktiv | Breathable
- ▶ 190T Polyester PU, 3000 mm Boden | Groundsheet
- ▶ Fiberglass 8,5 mm
- ▶ SBS Marken Reißverschluss | SBS brand zipper
- ▶ Extra starke 5 mm Erdnägel | Durable, strong 5 mm pegs
- ▶ Reißverschluß Packsack | Zipped pack sack

## Außenzelt | Fly sheet

- ▶ Wettergeschützter Eingang | Weather protected entrance
- ▶ Reißverschluss Abdeckklappe mit Regenrinne | Zipper flap with rain gusset
- ▶ XL Vorbau mit Stauraum | XL vestibule with storage space
- ▶ Angenähter Zeltboden an der Innenzelt front | Fixed vestibule floor on inner tent front
- ▶ Vorbau mit Faulstreifen | Vestibule with mudflap
- ▶ 2 Eingänge | 2 entries
- ▶ 2 Dauerventilationen | 2 permanent ventilations
- ▶ Extra großer Abstand zwischen Außenzelt u. Innenzelt. Luftzirkulierung | Roomy space between fly sheet and inner tent. Air circulation
- ▶ Gaze-Fenster mit Reißverschluss Abdeckklappe von innen zu bedienen | Mesh window with zipped cover to operate from inside
- ▶ Gut sichtbarer roter Bodenstreifen in der Dämmerung | Twilight visible red tape around bottom fly sheet
- ▶ Gestänge Markierung | Color marked poles

## Innenzelt | Inner tent

- ▶ Innenzelt vormontiert | Pre-mounted inner tent
- ▶ Extra lang 230 cm | Extra long 230 cm
- ▶ Doppeltür mit ganzflächigem Gaze-Eingang | Dual entry with full mesh door
- ▶ Easy stow away Tür-System | Easy stow away door system
- ▶ Wannenboden | Tub floor
- ▶ Innentaschen | Inner pockets
- ▶ Lampenhalter | Lamp holder



## FALCON 3

Art.-Nr./No. 10329 | EAN 4001690103299 | VPE/PU 4

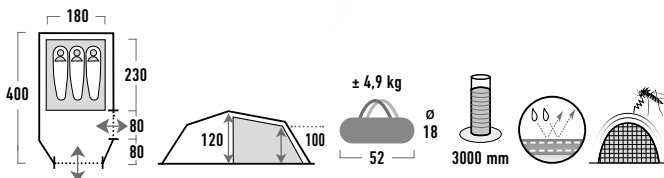

# FALCON 4 LW

**Leichtgewicht-Tunnelzelt mit Vorbau mit Aluminium-Gestänge | Lightweight tunnel tent with vestibule with aluminium poles**



Aluminium Gestänge 7001 T6 | Aluminium poles 7001 T6



Sehr stabil | High stability



Gewicht | Weight: 4,8 kg



Langlebig | Durable



Kleines Packmaß | Small pack size



Aluminium Erdnägel | Aluminium pegs



Video

- ▶ Pesto-rot | Pesto-red
- ▶ 190T Polyester PU, 3000 mm
- ▶ Polyester atmungsaktiv | Breathable
- ▶ 190T Polyester PU, 3000 mm Boden | Groundsheet
- ▶ Aluminium Gestänge 7001 T6 9,5 mm | Aluminium poles
- ▶ SBS Marken Reißverschluss | SBS brand zipper
- ▶ Aluminium Erdnägel | Peg
- ▶ Reißverschluss Packsack | Zipped pack sack

## Außenzelt | Fly sheet

- ▶ Wettergeschützter Eingang | Weather protected entrance
- ▶ Reißverschluss Abdeckklappe mit Regenrinne | Zipper flap with rain gusset
- ▶ XL Vorbau mit Stauraum | XL vestibule with storage space
- ▶ Angenähter Zeltboden an der Innenzelt front | Fixed vestibule floor on inner tent front
- ▶ Vorbau mit Faulstreifen | Vestibule with mudflap
- ▶ 2 Eingänge | 2 entries
- ▶ 2 Dauerventilationen | 2 permanent ventilations
- ▶ Extra großer Abstand zwischen Außenzelt u. Innenzelt. Luftzirkulierung | Roomy space between fly sheet and inner tent. Air circulation
- ▶ Gaze-Fenster mit Reißverschluss Abdeckklappe von innen zu bedienen | Mesh window with zippered cover to operate from inside
- ▶ Gut sichtbarer roter Bodenstreifen in der Dämmerung | Twilight visible red tape around bottom fly sheet
- ▶ Gestänge Markierung | Color marked poles

## Innenzelt | Inner tent

- ▶ Innenzelt vormontiert | Pre-mounted inner tent
- ▶ Extra lang 230 cm | Extra long 230 cm
- ▶ Doppeltür mit ganzflächigem Gaze-Eingang | Dual entry with full mesh door
- ▶ Easy stow away Tür-System | Easy stow away door system
- ▶ Wannenboden | Tub floor
- ▶ Innentaschen | Inner pockets
- ▶ Lampenhalter | Lamp holder

EXTRA LIGHTWEIGHT



## FALCON 4 LW

Art.-Nr./No. 10334 | EAN 4001690103343 | VPE/PU 2

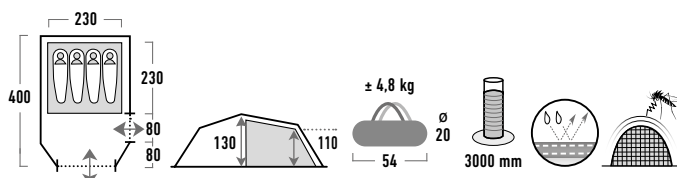

# FALCON 4

Tunnelzelt mit Vorbau |  
Tunnel tent with vestibule



Video

TENTS

ZELTE

- ▶ Pesto-rot | Pesto-red
- ▶ 190T Polyester PU, 3000 mm
- ▶ Polyester atmungsaktiv | Breathable
- ▶ 190T Polyester PU, 3000 mm Boden | Groundsheet
- ▶ Fiberglass 9,5 mm
- ▶ SBS Marken Reißverschluss | SBS brand zipper
- ▶ Extra starke 5 mm Erdnägel | Durable, strong 5 mm pegs
- ▶ Reißverschlus Packsack | Zipped pack sack

## Außenzelt | Fly sheet

- ▶ Wettergeschützter Eingang | Weather protected entrance
- ▶ Reißverschluss Abdeckklappe mit Regenrinne | Zipper flap with rain gusset
- ▶ XL Vorbau mit Stauraum | XL vestibule with storage space
- ▶ Angenähter Zeltboden an der Innenzelt front | Fixed vestibule floor on inner tent front
- ▶ Vorbau mit Faulstreifen | Vestibule with mudflap
- ▶ 2 Eingänge | 2 entries
- ▶ 2 Dauerventilationen | 2 permanent ventilations
- ▶ Extra großer Abstand zwischen Außenzelt u. Innenzelt. Luftzirkulierung | Roomy space between fly sheet and inner tent. Air circulation
- ▶ Gaze-Fenster mit Reißverschluss Abdeckklappe von innen zu bedienen | Mesh window with zipped cover to operate from inside
- ▶ Gut sichtbarer roter Bodenstreifen in der Dämmerung | Twilight visible red tape around bottom fly sheet
- ▶ Gestänge Markierung | Color marked poles

## Innenzelt | Inner tent

- ▶ Innenzelt vormontiert | Pre-mounted inner tent
- ▶ Extra lang 230 cm | Extra long 230 cm
- ▶ Doppeltür mit ganzflächigem Gaze-Eingang | Dual entry with full mesh door
- ▶ Easy stow away Tür-System | Easy stow away door system
- ▶ Wannenboden | Tub floor
- ▶ Innentaschen | Inner pockets
- ▶ Lampenhalter | Lamp holder



## FALCON 4

Art.-Nr./No. 10327 | EAN 4001690103275 | VPE/PU 2

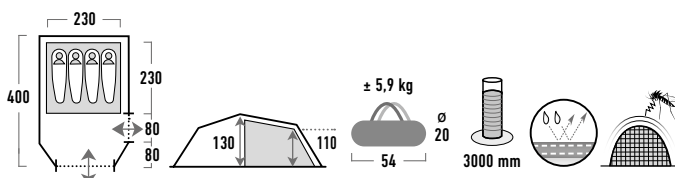

# GOOSE 4 LW

**Leichtgewicht Vis á Vis Tunnelzelt  
mit Aluminium-Gestänge |  
Lightweight Vis á Vis tunnel tent  
with aluminium poles**



Aluminium Gestänge 7001 T6 |  
Aluminium poles 7001 T6



Sehr stabil |  
High stability



Gewicht |  
Weight: 7,9 kg



Langlebig |  
Durable



Kleines Packmaß |  
Small pack size



Aluminium Erdnägel |  
Aluminium pegs

- ▶ Pesto-rot | Pesto-red
- ▶ 190T Polyester PU, 3000 mm
- ▶ Polyester atmungsaktiv | Breathable
- ▶ 190T Polyester PU, 3000 mm Boden | Ground sheet
- ▶ Aluminium Gestänge 7001 T6 11,0 mm | Aluminium poles
- ▶ SBS Marken Reißverschluss | SBS brand zipper
- ▶ Aluminium Erdnägel | Peg
- ▶ Robuster Roll-down Packsack mit Kompressionsgurten |  
Durable roll-down packsac with compression straps

**EXTRA  
LIGHTWEIGHT**

## Innenzelt | Inner tent

- ▶ 2 Innenzelte | 2 inner tents
- ▶ Wannboden | Tub floor
- ▶ Doppeltür mit ganzflächigem Gaze-Eingang | Dual entry with full mesh door
- ▶ Boden-Schnellbefestigungshaken | Floor quick fastening hooks
- ▶ Positionsmarkierung passend zum Außenzelt erleichtern das Einhängen |  
Corresponding color code matching to outer tent for easy set up
- ▶ Organizer | Organizer
- ▶ Innentaschen | Inner pockets
- ▶ Lampenhalter | Lamp holder
- ▶ Trockenleine | Dry cord



## GOOSE 4 LW

Art.-Nr./No. **10333** | EAN **4001690103336** | VPE/PU 1

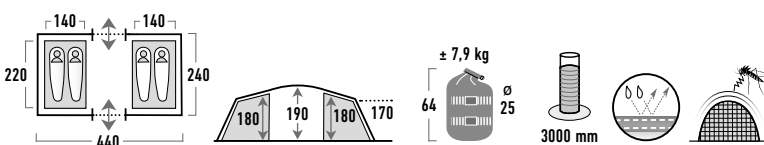

## Außenzelt | Fly sheet

- ▶ Wohnraum mit 2 Eingängen und Faulstreifen | Living area with 2 entrances and mudflap
- ▶ Reißverschluss Abdeckklappe mit Regenrinne | Zipper flap with rain gusset
- ▶ Gaze-Fenster | Mesh window
- ▶ Herausnehmbarer Wannboden | Detachable bath tube floor
- ▶ 2 »Advanced Low Vent« System Bodenventilationen |
- ▶ 2 »Advanced Low Vent« System ground ventilations
- ▶ 2 große Dauerventilationen im Schlafbereich mit Abspannfunktion |
- ▶ 2 oversized permanent ventilation's with guy out function
- ▶ Extra großer Abstand zwischen Außenzelt u. Innenzelt.
- ▶ Luftzirkulierung | Roomy space between fly sheet and inner tent. Air circulation
- ▶ Verstellbare Gurtbänder | Adjustable tensioning straps
- ▶ Gut sichtbarer roter Bodenstreifen in der Dämmerung |
- ▶ Twilight visible red tape around bottom fly sheet
- ▶ Gestänge Markierung | Color marked poles



Video



- ▶ Gaze-Fenster | Mesh window



- ▶ 2 große Dauerventilationen im Schlafbereich mit Abspannfunktion |
- ▶ 2 oversized permanent ventilation's with guy out function
- ▶ 2 »Advanced Low Vent« System Bodenventilationen |
- ▶ 2 »Advanced Low Vent« System ground ventilations

# WOODPECKER 3 LW

**Freistehendes Leichtgewicht  
Trekking Kuppelzelt  
mit Aluminium-Gestänge |  
Self supporting lightweight  
trekking dome tent  
with aluminium poles**

- ✓ Aluminium Gestänge 7001 T6 |  
Aluminium poles 7001 T6
- ✓ Gewicht |  
Weight: 3,0 kg
- ✓ Kleines Packmaß |  
Small pack size

- ✓ Sehr stabil |  
High stability
- ✓ Langlebig |  
Durable
- ✓ Aluminium Erdnägel |  
Aluminium pegs



Video

- ▶ Pesto-rot | Pesto-red
- ▶ 190T Polyester PU
- ▶ Polyester atmungsaktiv | Breathable
- ▶ 190T Polyester PU Boden | Groundsheet
- ▶ Aluminium Gestänge 7001 T6  
7,9 mm / 11 mm |  
Aluminium poles
- ▶ SBS Marken Reißverschluss |  
SBS brand zipper
- ▶ Aluminium Erdnägel | Peg  
▶ Reißverschluss Tragetasche |  
zipped carry bag

## Außenzelt | Fly sheet

- ▶ Dachgestänge bildet 2 wettergeschützte Eingänge mit Stauraum |  
Ridge pole creates 2 weather protected entrances and storage
- ▶ 2 Dauerventilationen mit Abstandshalter |  
2 permanent ventilations with distance holder
- ▶ Durchgehende Gestänge-Kanäle für schnellen Aufbau |  
Quick erect continuous pole sleeves
- ▶ Gut sichtbarer roter Bodenstreifen in der Dämmerung |  
Twilight visible red tape around bottom fly sheet
- ▶ Gestänge Markierung | Color marked poles

## Innenzelt | Inner tent

- ▶ Innenzelt vormontiert | Pre-mounted inner tent
- ▶ Doppeltür mit ganzflächigem Gaze-Eingang |  
Dual entry with full mesh door
- ▶ Wannenboden | Tub floor
- ▶ Innentaschen | Inner pockets
- ▶ Lampenhalter | Lamp holder

**EXTRA  
LIGHTWEIGHT**

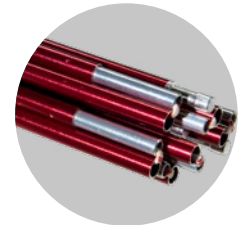

## WOODPECKER 3 LW

Art.-Nr./No. 10195 | EAN 4001690101950 | VPE/PU 4





# WOODPECKER 3

Freistehendes Trekking Kuppelzelt |  
Self supporting trekking dome tent



Video

TENTS

ZELTE

- ▶ Pesto-rot | Pesto-red
- ▶ 190T Polyester PU
- ▶ Polyester atmungsaktiv | Breathable
- ▶ 190T Polyester Boden | Groundsheet
- ▶ Fiberglass 7,9 mm / 11 mm
- ▶ SBS Marken Reißverschluss | SBS brand zipper
- ▶ Reißverschluss Tragetasche | Zipped carry bag

## Außenzelt | Fly sheet

- ▶ Dachgestänge bildet 2 wettergeschützte Eingänge mit Stauraum | Ridge pole creates 2 weather protected entrances and storage
- ▶ 2 Dauerventilationen mit Abstandshalter | 2 permanent ventilations with distance holder
- ▶ Durchgehende Gestänge-Kanäle für schnellen Aufbau | Quick erect continuous pole sleeves
- ▶ Gut sichtbarer roter Bodenstreifen in der Dämmerung | Twilight visible red tape around bottom fly sheet
- ▶ Gestänge Markierung | Color marked poles

## Innenzelt | Inner tent

- ▶ Innenzelt vormontiert | Pre-mounted inner tent
- ▶ Doppeltür mit ganzflächigem Gaze-Eingang | Dual entry with full mesh door
- ▶ Wannboden | Tub floor
- ▶ Innentaschen | Inner pockets
- ▶ Lampenhalter | Lamp holder



## WOODPECKER 3

Art.-Nr./No. **10194** | EAN **4001690101943** | VPE/PU 4

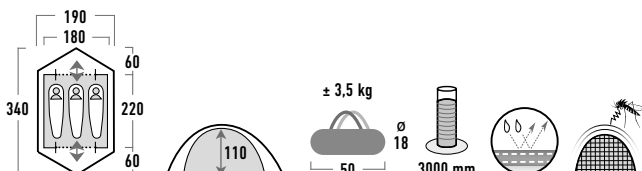



# Camping-Festival

## Camping-Festival

### ZIELGRUPPE | TARGET GROUP

Camping – Festival

### EIGENSCHAFTEN | PERFORMANCE

Leichter Aufbau – vielseitig | Easy set up – versatile

### EINSATZBEREICH | APPLICATION

1-2 Jahreszeiten | 1-2 seasons

### AUSSTATTUNG |

#### FEATURES

- ▶ Nahtversiegelt – wasserdicht | Seam sealed - waterproof
- ▶ Dauer- Ventilation | Permanent ventilation
- ▶ Eingang mit Gazefenster | Entrance with mesh window
- ▶ „SBS“ Reißverschluss, Querfestigkeit 600-800 N | „SBS“ zipper, lateral strength 600-800 N
- ▶ Innentaschen | Inner pockets
- ▶ Lampenhalter | Lamp holder



Lampenhalterung |  
Lamp holder



SBS Qualitäts- Reißverschluss |  
SBS quality zipper

Hochwertiges Polyester PU beschichtet 2000 mm,  
wasserdicht durch Nahtversiegelung |  
Quality polyester PU coated 2000 mm,  
seam sealed, waterproof



Atmungsaktives Innenzelt  
mit Wanneboden |  
Breathable inner tent with tub floor

Eingang mit Gazeeinsatz |  
Entry with mesh window



Hochentlüftung | Top ventilation

Extra breiter Rundbogen-Eingang |  
Extra wide arch shaped door

Wanneboden |  
Tub floor

Hochwertiges Polyester PU beschichtet 1500 mm,  
wasserdicht durch Nahtversiegelung |  
Quality polyester PU coated 1500 mm,  
seam sealed, waterproof

## KIRUNA

Freistehendes Kuppelzelt |  
Self supporting dome tent

- ▶ 190T Polyester PU
- ▶ Polyester atmungsaktiv | Breathable
- ▶ PE Boden | Groundsheet
- ▶ Fiberglass 7,9 mm
- ▶ SBS Marken Reißverschluss | SBS brand zipper
- ▶ SBS brand zipper
- ▶ Reißverschluss Tragetasche | Zipped carry bag

## Außenzelt | Fly sheet

- ▶ Extra breiter Apsiden-Eingang | Extra wide vestibule entrance
- ▶ Dauerventilation mit Abstandhalter | Permanent ventilation with distance holder

## Innenzelt | Inner tent

- ▶ Eingang mit Gazeeinsatz | Door with mesh window
- ▶ Wannboden | Tub floor
- ▶ Innentaschen | Inner pockets
- ▶ Lampenhalter | Lamp holder



Video



## KIRUNA 2

Art.-Nr./No. 10305 | EAN 4001690103053 | VPE/PU 4

- ▶ Blau-grau | Blue-grey

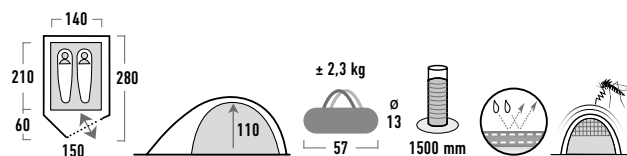

## KIRUNA 3

Art.-Nr./No. 10306 | EAN 4001690103060 | VPE/PU 4

- ▶ Blau-grau | Blue-grey

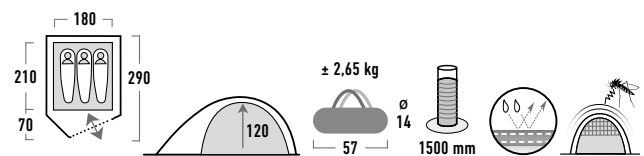

## KIRUNA 2

Art.-Nr./No. 10297 | EAN 4001690102971 | VPE/PU 4

- ▶ Schwarz | Black

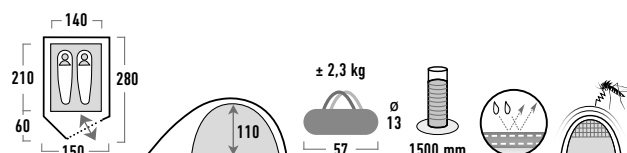

## KIRUNA 3

Art.-Nr./No. 10298 | EAN 4001690102988 | VPE/PU 4

- ▶ Schwarz | Black

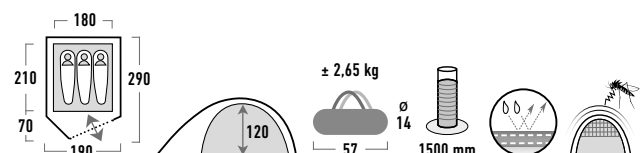

# KIRUNA 4

## Freistehendes Kuppelzelt | Self supporting dome tent

- ▶ 190T Polyester PU
- ▶ Polyester atmungsaktiv | Breathable
- ▶ PE Boden | Groundsheet
- ▶ Fiberglass 8,5 mm
- ▶ SBS Marken Reißverschluss | SBS brand zipper
- ▶ Reißverschluss Tragetasche | Zipped carry bag

## Außenzelt | Fly sheet

- ▶ Extra breiter Apsiden-Eingang | Extra wide vestibule entrance
- ▶ Dauerventilation mit Abstandhalter | Permanent ventilation with distance holder

## Innenzelt | Inner tent

- ▶ Eingang mit Gazeeinsatz | Door with mesh window
- ▶ Wannboden | Tub floor
- ▶ Innentaschen | Inner pockets
- ▶ Lampenhalter | Lamp holder



Video



## KIRUNA 4

Art.-Nr./No. **10309** | EAN **4001690103091** | VPE/PU 4

- ▶ Blau-grau | Blue-grey

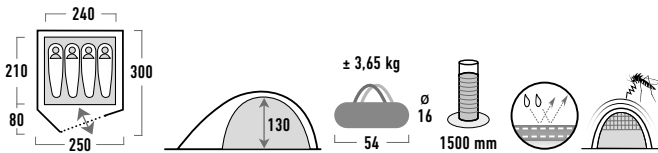

## KIRUNA 4

Art.-Nr./No. **10299** | EAN **4001690102995** | VPE/PU 4

- ▶ Schwarz | Black

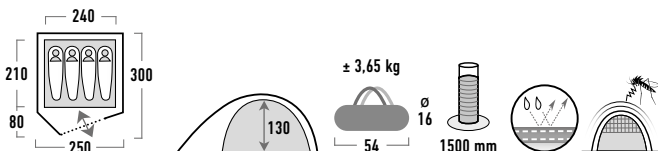

# MONODOME



Video

## Freistehendes Einfachdach Kuppelzelt | Self supporting single skin dome tent

- ▶ Blau-grau | Blue-grey
- ▶ 190T Polyester PU
- ▶ PE Boden | Groundsheet
- ▶ Fiberglass 7,9 mm
- ▶ SBS Marken Reißverschluss |  
SBS brand zipper
- ▶ Reißverschluss Tragetasche |  
Zipped carry bag
- ▶ Rundbogen-Eingang | Round shaped arch entry
- ▶ Hochentlüftung | Top ventilation
- ▶ Wannboden | Tub floor
- ▶ Doppeltür mit ganzflächigem Gaze-Eingang |  
Dual entry with full mesh door
- ▶ Innentaschen | Inner pockets
- ▶ Lampenhalter | Lamp holder



## MONODOME

Art.-Nr./No. **10159** | EAN **4001690101592** | VPE/PU **6**

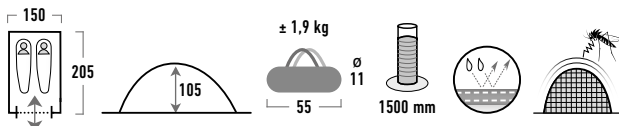

# MONODOME XL



VIDEO

## Freistehendes Einfachdach Kuppelzelt | Self supporting single skin dome tent

- ▶ 190T Polyester PU
- ▶ PE Boden | Groundsheet
- ▶ Fiberglass 7,9 mm
- ▶ SBS Marken Reißverschluss | SBS brand zipper
- ▶ Reißverschluss Tragetasche | Zipped carry bag

- ▶ Extra breiter Rundbogen-Eingang | Extra wide round shaped arch entry
- ▶ Große Hochentlüftung | Large top ventilation
- ▶ Wannboden | Tub floor
- ▶ Doppeltür mit ganzflächigem Gaze-Eingang | Dual entry with full mesh door
- ▶ Innentaschen | Inner pockets
- ▶ Lampenhalter | Lamp holder



## MONODOME XL

Art.-Nr./No. **10164** | EAN **4001690101646** | VPE/PU 4

- ▶ Blau-grau | Blue-grey

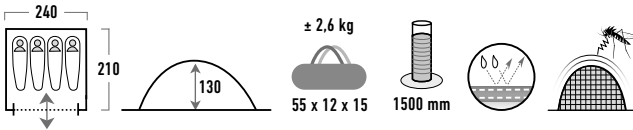

## MONODOME XL

Art.-Nr./No. **10310** | EAN **4001690103107** | VPE/PU 4

- ▶ Schwarz | Black

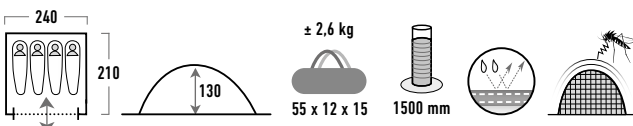

# BEAVER 3

Freistehendes  
Einfachdach Kuppelzelt |  
Self supporting  
single skin dome tent

- ▶ 190T Polyester PU
- ▶ PE Boden | Groundsheet
- ▶ Fiberglass 7,9 mm · Stahl | Steel 16 mm
- ▶ SBS Marken Reißverschluss |  
SBS brand zipper
- ▶ Reißverschluss Tragetasche |  
Zipped carry bag



## BEAVER 3

Art.-Nr./No. **10167** | EAN **4001690101677** | VPE/PU 6

- ▶ Blau-grau | Blue-grey
- ▶ 190T Polyester PU

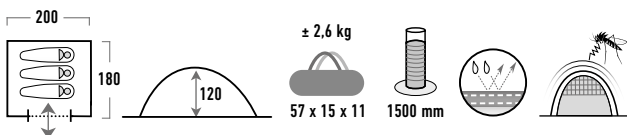



- ▶ Wetterschutz-Eingang mit Aufstellstangen | Weather protected entry with upright poles
- ▶ Eingang mit Gazeinsatz | Door with mesh window
- ▶ Hochentlüftung | Top ventilation
- ▶ Wannenfoden | Tub floor
- ▶ Innentaschen | Inner pockets
- ▶ Lampenhalter | Lamp holder



Video



## BEAVER 3

Art.-Nr./No. **10320** | EAN **4001690103206** | VPE/PU 6

▶ Schwarz | Black

▶ 190T Polyester PU



## MINILITE

Einfachdach Giebelzelt |  
Single skin canadian style tent

- ▶ Blau-grau | blue-grey
- ▶ 190T Polyester PU
- ▶ 190T Polyester Boden | Groundsheet
- ▶ Fiberglass 9,5 mm
- ▶ SBS Marken Reißverschluss | SBS brand zipper
- ▶ Reißverschluss Tragetasche | Zipped carry bag

- ▶ Doppeltür mit ganzflächigem Gaze-Eingang | Dual entry with full mesh door
- ▶ 2 Dauerventilationen | 2 permanent ventilations
- ▶ Innentaschen | Inner pockets
- ▶ Lampenhalter | Lamp holder



video



## MINILITE

Art.-Nr./No. 10157 | EAN 4001690101578 | VPE/PU 6/12

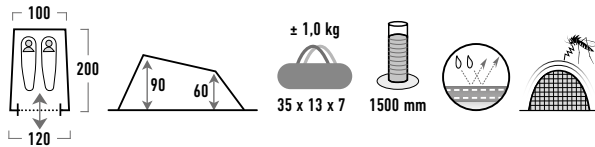

## MINIPACK

Einfachdach Hauszelt |  
Single skin canadian style tent

- ▶ Blau-grau | blue-grey
- ▶ 190T Polyester PU
- ▶ PE Boden | Groundsheet
- ▶ Stahl | Steel 16 mm
- ▶ SBS Marken Reißverschluss | SBS brand zipper
- ▶ Reißverschluss Tragetasche | Zipped carry bag

- ▶ Doppeltür mit ganzflächigem Gaze-Eingang | Dual entry with full mesh door
- ▶ Seitenwände | Side walls
- ▶ Wannensboden | Tub floor
- ▶ 2 Dauerventilationen | 2 permanent ventilations
- ▶ Innentaschen | Inner pockets
- ▶ Lampenhalter | Lamp holder



Video



## MINIPACK

Art.-Nr./No. 10155 | EAN 4001690101554 | VPE/PU 6

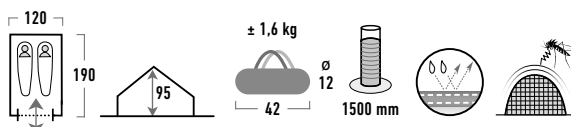

# ONTARIO 3

## Einfachdach Kuppelzelt mit Vorbau | Single skin dome tent with vestibule

- ▶ Blau-grau | blue-grey
- ▶ 190T Polyester PU
- ▶ PE Boden | Groundsheet
- ▶ Fiberglass 7,9 mm
- ▶ SBS Marken Reißverschluss |  
SBS brand zipper
- ▶ Reißverschluss Tragetasche |  
Zipped carry bag

- ▶ Wetterschutz-Eingang | Weather protected entry
- ▶ Vorbau mit Faulstreifen | Vestibule incl. mudflap
- ▶ Eingang mit Gazeinsatz | Door with mesh window
- ▶ Hochentlüftung | Top ventilation
- ▶ Wannenföden | Tub floor
- ▶ Innentaschen | Inner pockets
- ▶ Lampenhalter | Lamp holder



Video



## ONTARIO 3

Art.-Nr./No. 10171 | EAN 4001690101714 | VPE/PU 4



# VISION 2

## Einfachdach Pop Up Zelt | Single skin pop up tent

- ▶ 190T Polyester PU
- ▶ 190T Polyester PU Boden | Groundsheet
- ▶ Fiberglass 5 mm
- ▶ SBS Marken Reißverschluss | SBS brand zipper
- ▶ Reißverschluss Tragetasche | Zipped carry bag

- ▶ Freistehend | Self supporting
- ▶ Doppeltür mit Gazeinsatz | Dual entry with full mesh window
- ▶ 2 Dauerventilationen mit Abstandhalter | 2 permanent ventilations with distance holder
- ▶ Extra große Ventilation mit Abspann Funktion | Oversized ventilation with guy out function
- ▶ Innentaschen | Inner pockets
- ▶ Lampenhalter | Lamp holder



video



## VISION 2

Art.-Nr./No. **10108** | EAN **4001690101080** | VPE/PU 4

- ▶ Grün-phantom | Green-phantom

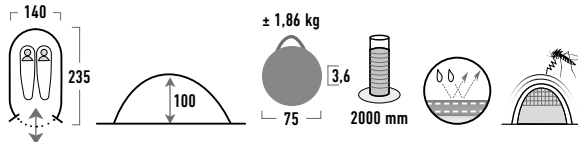

## VISION 2

Art.-Nr./No. **10280** | EAN **4001690102803** | VPE/PU 4

- ▶ Schwarz | Black

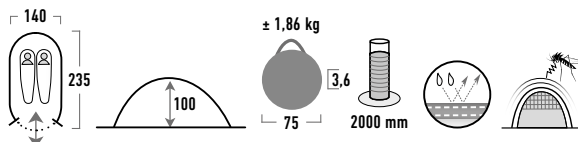

# VISION 3

## Einfachdach Pop Up Zelt | Single skin pop up tent

- ▶ 190T Polyester PU
- ▶ 190T Polyester PU Boden | Groundsheet
- ▶ Fiberglass 6 mm
- ▶ SBS Marken Reißverschluss | SBS brand zipper
- ▶ Reißverschluss Tragetasche | Zipped carry bag

- ▶ Freistehend | Self supporting
- ▶ Doppeltür mit Gazeinsatz | Dual entry with full mesh window
- ▶ 2 Dauerventilationen mit Abstandhalter | 2 permanent ventilations with distance holder
- ▶ Extra große Ventilation mit Abspann Funktion | Oversized ventilation with guy out function
- ▶ Innentaschen | Inner pockets
- ▶ Lampenhalter | Lamp holder



video



# VISION 3

Art.-Nr./No. **10123** | EAN **4001690101233** | VPE/PU 3

- ▶ Grün-phantom | Green-phantom

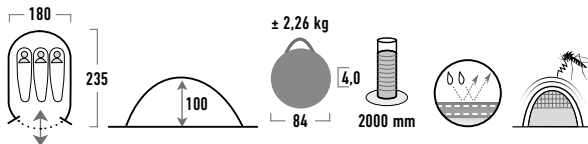

# VISION 3

Art.-Nr./No. **10290** | EAN **4001690102902** | VPE/PU 3

- ▶ Schwarz | Black

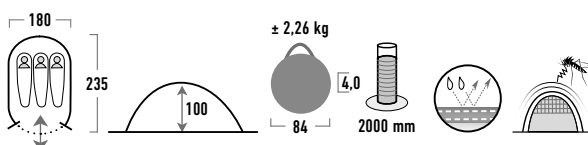

# Buszelte

## Drive Away Awnings

### ZIELGRUPPE | TARGET GROUP

Reisemobil | Camper Vans

### EIGENSCHAFTEN | PERFORMANCE

Vielseitiges Design – Flexibler Einsatz –  
Multikompatible Fahrzeug-Anbindungssysteme |  
Functional / versatile design – flexible use –  
multi compatible car connector system

### EINSATZBEREICH | APPLICATION

3 Jahreszeiten | 3 seasons

### AUSSTATTUNG | FEATURES

- ▶ Nahtversiegelt, wasserdicht | Seam sealed, waterproof
- ▶ Klarsichtfolienfenster mit Abdeckung | Crystal clear window with cover
- ▶ Anschlusshöhe 170-220 cm | Connection height 170-220 cm
- ▶ Doppelkeder 5,8 / 7,2 mm | Double kador strip 5,8 / 7,2 mm
- ▶ Hohlraum-Schleusenstab mit 3 Klemmen | Sleeve pole and 3 clamps
- ▶ 3 Klettbandschlaufen | 3 touch fastener



### PREMIUM AUSSTATTUNG | PREMIUM FEATURES

- ▶ Eingenähter- oder herausnehmbarer Zeltboden | Zip in- or detachable ground sheet
- ▶ Klarsichtfolienfenster mit Vario RV Abdeckung | Crystal clear window with zipped vario cover
- ▶ 150 D „Superfine“ Gazefenster mit Vario RV Abdeckung | 150 D „superfine“ mesh window with zipped vario cover
- ▶ Hochentlüftung | Top ventilation
- ▶ 4 abnehmbare Sicherheits- Sturmbänder | 4 detachable safety storm bands
- ▶ RV Kabeleingang | Zipped cable point entry
- ▶ Teilbare Rückwand | Divisible rear wall
- ▶ Anschlusshöhe von 180-240 cm variabel mittels RV | Connection height 180-240 cm extendable by zipper
- ▶ Abnehmbarer Keder mittels Reißverschluss | Detachable kador by zipper
- ▶ 3 Klettbandschlaufen | 3 touch fastener
- ▶ 3 extra breite, 5 cm abnehmbare Quick Fix Dachbänder | 3 extra wide, 5 cm detachable Quick Fix roof bands
- ▶ Schleuse mit 2 Eingängen | Rear attachment tunnel with 2 entries
- ▶ Aufrollbare Schleuse | Roll away attachment tunnel



Strapazierfähiges Qualitäts-Polyester 4000 mm,  
versiegelte Nähte, wasserdicht |  
Durable quality-polyester 4000 mm, seam sealed, waterproof

Hochentlüftung |  
Top ventilation



Abnehmbare Sicherheits-  
Sturmbänder |  
Detachable safety  
storm bands

Gaze Fenster von innen  
zu verschließen mittels RV |  
Mesh window with  
inside zipped cover

Eingenähter Boden, wasserdicht |  
Fully sewn-in ground sheet,  
water proof

Klarsichtfolien-Fenster von innen  
zu verschließen mittels RV |  
Crystal clear window with zipped inside cover

Variable Anschlusshöhe mittels RV |  
Variable connection height by zipper

Aufrollbare Schleuse |  
Roll away attachment tunnel



▶ Doppelkeder |  
Double kador strip  
▶ Hohlraum-Schleusenstab |  
Sleeve pole



▶ 3 Klettbandschlaufen  
für Dachreling |  
3 touch fastener roof  
bar attachment tabs



▶ Abnehmbarer Keder  
mittels RV:  
leichtes An-/Abdocken |  
Drive away zip system



▶ 3 extra breite 5 cm  
Quick Fix Dachbänder |  
3 extra wide 5 cm  
quick fix roof bands

# TRENTO 2.0

## Buszelt-Vordach | Touring shelter

- ▶ Hellgrau-dunkelgrau-lime | Light grey-dark grey-lime
- ▶ 190T Polyester PU 4000 mm
- ▶ Polyethylen Faulstreifen | Polyethylene mud flap
- ▶ Stahlgestänge | Steel frame 19 mm
- ▶ Stahl Schleusenstab | Steel rear link annex pole 16 mm
- ▶ Reißverschluss Tragetasche | Zipped carry bag

## Ausstattung | Features

- ▶ Rundbogendach | Arched shaped roof
- ▶ Klarsichtfolienfenster mit Abdeckung | Crystal clear window with cover
- ▶ 3 abnehmbare Sicherheits-Sturmbänder | 3 detachable safety storm bands
- ▶ Doppelkeder 5,8 / 7,2 mm | Double kador strip 5,8 / 7,2 mm
- ▶ Hohlraum-Schleusenstab | Sleeve tunnel for rear attachment pole
- ▶ 3 Klettbandschlaufen für Dachreling | 3 touch fastener roof bar attachment
- ▶ 2 Gurtbandschlaufen für Dach-Abspannleinen-Befestigung | 2 webbing loops for guyline roof fixation
- ▶ Anschlußhöhe 180-205 cm | Connection height 180-205 cm







- ▶ Doppelkeder | Double kador strip
- ▶ Hohlsaum-Schleusenstab | Sleeve pole



- ▶ 3 Klettbandschlaufen für Dachreling | 3 touch fastener roof bar attachment tabs

## TRENTO 2.0

Art.-Nr./No. **14180** | EAN **4001690141802** | VPE/PU 1



# AVIO 2.0

## Freistehendes Leichtgewicht Buszelt | Free standing lightweight awning

- ▶ Hellgrau-dunkelgrau-lime | Light grey-dark grey-lime
- ▶ 190T Polyester PU 4000 mm, nahtversiegelt | Seam taped
- ▶ 150D Polyester 120 gr<sup>2</sup> Super Strong Gaze | Mesh
- ▶ Polyethylen Faulstreifen | Polyethylene mud flap
- ▶ Fiberglass 11 mm
- ▶ Stahl Dach-Stützgestänge 19+16 mm verstellbar | Steel roof supporting poles 19+16 mm
- ▶ Stahl Schleusenstab | Steel rear link annex pole 16 mm
- ▶ Reißverschluss SBS # 8 | Zipper SBS # 8
- ▶ 150D Polyester Kompressions-Packsack | Compressions pack sac

## Ausstattung | Features

- ▶ 2 Klarsichtfolien-Fenster mit Abdeckung | 2 Crystal clear windows with cover
- ▶ 2 Gazefenster mit Vario RV Abdeckung | 2 mesh window with zipped vario cover
- ▶ 2 Dauerventilationen | 2 permanent ventilations
- ▶ Verschließbare, teilbare 50/50 Rückwand | Fully zipped rear wall divisible 50/50
- ▶ Faulsteifen | Mudflap



## AVIO 2.0

Art.-Nr./No. 14135 | EAN 4001690141352 | VPE/PU 1

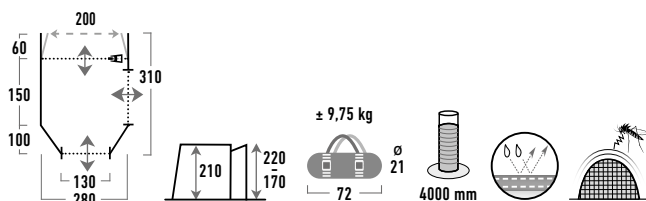

**Schleuse** | Attachment tunnel

- ▶ Anschlusshöhe 170-220 cm | Connection height 170-220 cm
- ▶ Schleusenbreite 200 cm | Connection width 200 cm
- ▶ Doppelkeder 5,8/7,2 mm | Double kador strip 5,8/7,2 mm
- ▶ Hohlsaum-Schleusenstab mit 3 Klemmen | Sleeve pole and 3 clamps
- ▶ 3 Klettbandschlaufen für Dachreling | 3 touch fastener roof bar attachment tabs



- ▶ Doppelkeder | Double kador strip
- ▶ Hohlsaum-Schleusenstab | Sleeve pole



- ▶ 3 Klettbandschlaufen für Dachreling | 3 touch fastener roof bar attachment tabs



# TRENTINO 2.0

## Freistehendes Buszelt | Free standing awning

- ▶ Hellgrau-dunkelgrau-lime | Light grey-dark grey-lime
- ▶ 190T Polyester PU 4000 mm, nahtversiegelt | Seam taped
- ▶ Polyethylen Zeltboden | Polyethylene ground sheet
- ▶ 150D Polyester 120 gr<sup>2</sup> Super Strong Gaze | Mesh
- ▶ Fiberglass 12,7/11 mm
- ▶ Stahl Aufstellstangen 16 mm | Steel upright poles 16 mm
- ▶ Stahl Schleusenstab | Steel rear link annex pole 16 mm
- ▶ Reißverschluss SBS # 8 | Zipper SBS # 8
- ▶ 150D Polyester Kompressions-Packsack | Compressions pack sac

## Ausstattung | Features

- ▶ Steilwand mit Rundbogendach für optimalen Raumnutzen | Pre-bended structure with curved roof offer great space
- ▶ Eingenähter Zeltboden mit externem Oxford Faulstreifen | Fully sewn-in ground sheet with external Oxford mud skirt
- ▶ Bodenwanne herunter klappbar | Ground sheet with fold down function
- ▶ 2 Klarsichtfolien-Fenster mit Vario RV Abdeckung | 2 crystal clear windows with zipped vario cover
- ▶ 2 Gazefenster mit Vario RV Abdeckung | 2 mesh windows with zipped vario cover
- ▶ Eingang mit Sonnendach Funktion | Door with canopy function
- ▶ Hochentlüftung | Top ventilation
- ▶ 4 abnehmbare Sicherheits-Sturmbänder | 4 detachable safety storm bands
- ▶ RV Kabeleingang | Zipped cable point entry
- ▶ Verschließbare, teilbare 50/50 Rückwand mit Easy Stow Away Tasche | Divisible 50/50 roll away connection door with Easy Stow Away pocket
- ▶ Option Innenzelt 14169 | Optional inner tent 14169



## TRENTINO 2.0

Art.-Nr./No. **14158** | EAN **4001690141581** | VPE/PU **1**

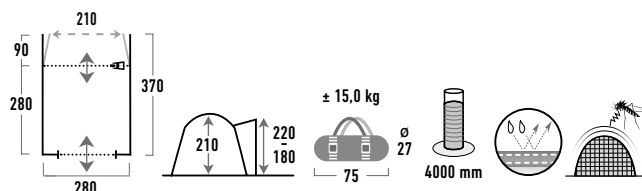

## INNENZELT Inner tent

Art.-Nr./No. **14169** | EAN **4001690141697** | VPE/PU **4**

- ▶ Polyester atmungsaktiv | Breathable
- ▶ Polyethylen Boden | Polyethylene groundsheet
- ▶ Eingang mit Gazefenster | Door with mesh window

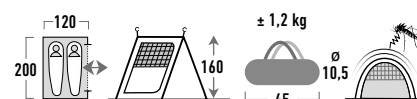

**Schleuse | Attachment tunnel**

- ▶ Anschlusshöhe 180-220 cm variabel mittels RV | Connection height 180-220 cm extendable by zipper
- ▶ Schleusenbreite 210 cm | Connection width 210 cm
- ▶ Doppelkeder 5,8/7,2 mm | Double kador strip 5,8/7,2 mm
- ▶ Hohlsaum-Schleusenstab mit 3 Klemmen | Sleeve pole and 3 clamps
- ▶ 3 Klettbandschlaufen für Dachreling | 3 touch fastener roof bar attachment tabs
- ▶ 3 extra breite 5 cm Quick Fix Dachbänder | 3 extra wide 5 cm quick fix roof bands
- ▶ Aufrollbare Schleuse | Roll away attachment tunnel



- ▶ Doppelkeder | Double kador strip
- ▶ Hohlsaum-Schleusenstab | Sleeve pole



- ▶ 3 Klettbandschlaufen für Dachreling | 3 touch fastener roof bar attachment tabs



- ▶ Abnehmbarer Keder mittels RV: leichtes An-/Abdocken | Drive away zip system



- ▶ 3 extra breite 5 cm Quick Fix Dachbänder | 3 extra wide 5 cm quick fix roof bands

# TOUR 2.0

## Freistehendes Buszelt | Free standing awning

- ▶ Hellgrau-dunkelgrau-lime | Light grey-dark grey-lime
- ▶ 190T Polyester PU 4000 mm, nahtversiegelt | Seam taped
- ▶ Polyethylen Zeltboden | Polyethylene ground sheet
- ▶ 150D Polyester 120 gr<sup>2</sup> Super Strong Gaze | Mesh
- ▶ Fiberglass 12,7 mm / 11,0 mm / 9,5 mm
- ▶ Stahl Schleusenstab | Steel rear link annex pole 16 mm
- ▶ Reißverschluss SBS # 10/8 | Zipper SBS # 10/8
- ▶ 150D Polyester Kompressions-Packsack | Compressions pack sac

## Ausstattung | Features

- ▶ Steilwand mit Rundbogendach für optimalen Raumnutzen | Pre-bended structure with curved roof offer great space
- ▶ Eingenähter Zeltboden mit externem Oxford Faulstreifen | Fully sewn-in ground sheet with external Oxford mud skirt
- ▶ Teilbare Veranda Front komplett zu öffnen | Divisible veranda front fully to open
- ▶ Veranda-Bodenwanne mittels Reißverschluss herunter klappbar | Veranda ground sheet with fold down function by zipper
- ▶ Gaze Seiteneingang mit Reißverschluss Einfassband nahtversiegelt | Mesh side entry with zipper fabric tape seamsealed
- ▶ 2 Klarsichtfolien-Fenster mit Vario RV Abdeckung | 2 crystal clear windows with zipped vario cover
- ▶ Gazefenster mit Vario RV Abdeckung | Mesh window with zipped vario cover
- ▶ Hochentlüftung | Top ventilation
- ▶ 4 abnehmbare Sicherheits-Sturmbänder | 4 detachable safety storm bands
- ▶ RV Kabeleingang | Zipped cable point entry
- ▶ Verschließbare, teilbare 50/50 Rückwand mit Easy Stow Away Tasche | Divisible 50/50 roll away connection door with Easy Stow Away pocket
- ▶ Option Innenzelt 14168 | Optional inner tent 14168



## TOUR 2.0

Art.-Nr./No. **14145** | EAN **4001690141451** | VPE/PU 1

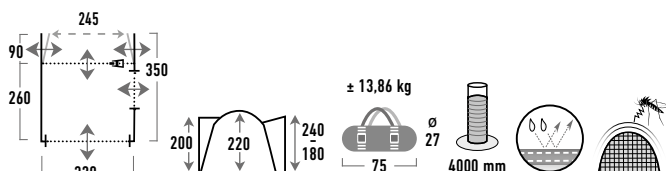

## INNENZELT Inner tent

Art.-Nr./No. **14168** | EAN **4001690141680** | VPE/PU 4

- ▶ Polyester atmungsaktiv | Breathable
- ▶ Polyethylen Boden | Polyethylene groundsheet
- ▶ Eingang mit Gazefenster | Door with mesh window

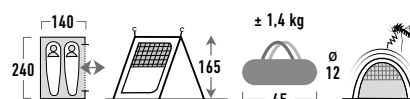

**Schleuse** | Attachment tunnel

- ▶ Anschlusshöhe 180-240 cm variabel mittels RV | Connection height 180-240 cm extendable by zipper
- ▶ Schleusenbreite 245 cm | Connection width 245 cm
- ▶ Doppelkeder 5,8/7,2 mm | Double kador strip 5,8/7,2 mm
- ▶ Hohlsaum-Schleusenstab mit 3 Klemmen | Sleeve pole and 3 clamps
- ▶ 3 Klettbandschlaufen für Dachreling | 3 touch fastener roof bar attachment tabs
- ▶ 3 extra breite 5 cm Quick Fix Dachbänder | 3 extra wide 5 cm quick fix roof bands
- ▶ Abnehmbarer Keder mittels RV ermöglicht leichtes An- und Abdocken am Fahrzeug | Drive away zip system
- ▶ Schleuse mit 2 Eingängen | Rear porch with 2 entries
- ▶ Aufrollbare Schleuse | Roll away attachment tunnel



- ▶ Doppelkeder | Double kador strip
- ▶ Hohlsaum-Schleusenstab | Sleeve pole



- ▶ 3 Klettbandschlaufen für Dachreling | 3 touch fastener roof bar attachment tabs



- ▶ Abnehmbarer Keder mittels RV: leichtes An-/Abdocken | Drive away zip system



- ▶ 3 extra breite 5 cm Quick Fix Dachbänder | 3 extra wide 5 cm quick fix roof bands

# RIVA 2.0

## Freistehendes Buszelt | Free standing awning

- ▶ Hellgrau-dunkelgrau-lime | Light grey-dark grey-lime
- ▶ 190T Polyester PU 4000 mm, nahtversiegelt | Seam taped
- ▶ Polyethylen Zeltboden | Polyethylene ground sheet
- ▶ 150D Polyester 120 gr<sup>2</sup> Super Strong Gaze | Mesh
- ▶ Stahl | Steel 19 mm · Fiberglass 11/8,5 mm
- ▶ Stahl Dach- Stützgestänge 19+16 mm verstellbar | Steel roof supporting poles 19+16 mm
- ▶ Stahl Schleusenstab | Steel rear link annex pole 16 mm
- ▶ Reißverschluss SBS # 10/8 | Zipper SBS # 10/8
- ▶ 150D Polyester Kompressions-Packsack | Compressions pack sac

## Ausstattung | Features

- ▶ Steilwand mit Rundbogendach für optimalen Raumnutzen | Pre-bended structure with curved roof offer great space
- ▶ Eingenähter Zeltboden mit externem Oxford Faulstreifen | Fully sewn-in ground sheet with external Oxford mud skirt
- ▶ Vordach | Porch
- ▶ Teilbare Front komplett zu öffnen | Divisible front fully to open
- ▶ Veranda-Bodenwanne mittels Reißverschluss herunter klappbar | Veranda ground sheet with fold down function by zipper
- ▶ Panorama Fenster Front mit Vario RV Abdeckung | panoramic crystal clear window front with zipped vario cover
- ▶ Klarsichtfolien-Fenster mit Vario RV Abdeckung | Crystal clear window with zipped vario cover
- ▶ Gazefenster mit Vario RV Abdeckung | Mesh window with zipped vario cover
- ▶ Gaze Seiteneingang mit Reißverschluss Einfassband nahtversiegelt | Mesh side entry with zipper fabric tape seamsealed
- ▶ Hochentlüftung | Top ventilation
- ▶ 4 abnehmbare Sicherheits-Sturmbänder | 4 detachable safety storm bands
- ▶ RV Kabeingang | Zipped cable point entry
- ▶ Verschließbare, teilbare 50/50 Rückwand mit Easy Stow Away Tasche | Divisible 50/50 roll away connection door with Easy Stow Away pocket
- ▶ Option Innenzelt 14160 | Optional inner tent 14160



## RIVA 2.0

Art.-Nr./No. **14138** | EAN **4001690141383** | VPE/PU **1**

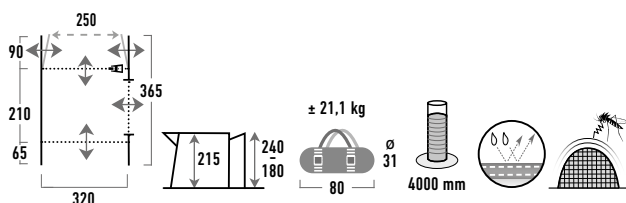

## INNENZELT Inner tent

Art.-Nr./No. **14160** | EAN **4001690141604** | VPE/PU **4**

- ▶ Polyester atmungsaktiv | Breathable
- ▶ Polyethylen Boden | Polyethylene groundsheet
- ▶ Eingang mit Gazefenster | Door with mesh window

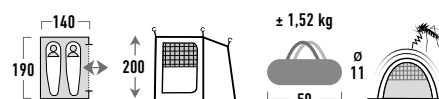



**Schleuse | Attachment tunnel**

- ▶ Anschlusshöhe 180-240 cm variabel mittels RV | Connection height 180-240 cm extendable by zipper
- ▶ Schleusenbreite 250 cm | Connection width 250 cm
- ▶ Doppelkeder 5,8/7,2 mm | Double kador strip 5,8/7,2 mm
- ▶ Hohlsaum-Schleusenstab mit 3 Klemmen | Sleeve pole and 3 clamps
- ▶ 3 Klettbandschlaufen für Dachreling | 3 touch fastener roof bar attachment tabs
- ▶ 3 extra breite 5 cm Quick Fix Dachbänder | 3 extra wide 5 cm quick fix roof bands
- ▶ Abnehmbarer Keder mittels RV ermöglicht leichtes An- und Abdocken am Fahrzeug | Drive away zip system
- ▶ Schleuse mit 2 Eingängen | Rear porch with 2 entries
- ▶ Aufrollbare Schleuse | Roll away attachment tunnel

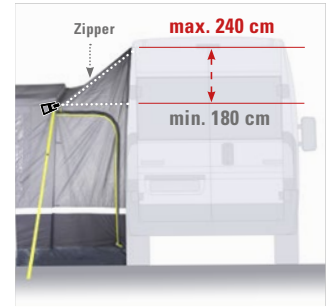

- ▶ Doppelkeder | Double kador strip
- ▶ Hohlsaum-Schleusenstab | Sleeve pole



- ▶ 3 Klettbandschlaufen für Dachreling | 3 touch fastener roof bar attachment tabs



- ▶ Abnehmbarer Keder mittels RV: leichtes An-/Abdocken | Drive away zip system



- ▶ 3 extra breite 5 cm Quick Fix Dachbänder | 3 extra wide 5 cm quick fix roof bands

# TRAMP 2.0

## Freistehendes Buszelt | Free standing awning

- ▶ Hellgrau-dunkelgrau-lime | Light grey-dark grey-lime
- ▶ 150D Hypertex Polyester PU 4000 mm, nahtversiegelt | Seam taped
- ▶ Polyethylen Zeltboden | Polyethylene ground sheet
- ▶ PVC Faulstreifen | PVC mud flap
- ▶ 150D Polyester 120 gr<sup>2</sup> Super Strong Gaze | Mesh
- ▶ Stahl | Steel 22 mm
- ▶ Stahl Schleusenstab | Steel rear link annex pole 16 mm
- ▶ Reißverschluss SBS # 10 | Zipper SBS # 10
- ▶ 150D Polyester Packsack | Pack sac

## Ausstattung | Features

- ▶ Steilwand Konstruktion für optimalen Raumnutzen | Straight walls offer great space
- ▶ Einhängbarer Zelt-Wannenboden | Bathtub floor attachable with toggle & ring system
- ▶ Teilbare Veranda Front komplett zu öffnen | Divisible veranda front fully to open
- ▶ 2 Klarsichtfolien-Fenster mit Vario RV Abdeckung | 2 crystal clear windows with zipped vario cover
- ▶ Gazefenster mit Vario RV Abdeckung | Mesh window with zipped vario cover
- ▶ 4 abnehmbare Sicherheits-Sturmbänder | 4 detachable safety storm bands
- ▶ Verschließbare, teilbare 50/50 Rückwand mit Easy Stow Away Tasche | Divisible 50/50 roll away connection door with Easy Stow Away pocket
- ▶ Option Innenzelt 14161 | Optional inner tent 14161



## TRAMP 2.0

Art.-Nr./No. **14142** | EAN **4001690141420** | VPE/PU **1**

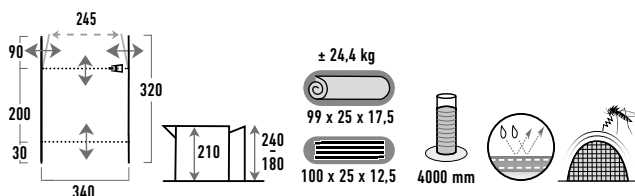

## INNENZELT Inner tent

Art.-Nr./No. **14161** | EAN **4001690141611** | VPE/PU **4**

- ▶ Polyester atmungsaktiv | Breathable
- ▶ Polyethylen Boden | Polyethylene groundsheet
- ▶ Eingang mit Gazefenster | Door with mesh window

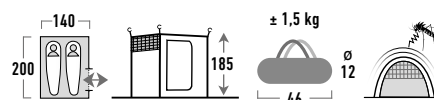

**Schleuse** | Attachment tunnel

- ▶ Anschlusshöhe 180-240 cm variabel mittels RV | Connection height 180-240 cm extendable by zipper
- ▶ Schleusenbreite 245 cm | Connection width 245 cm
- ▶ Doppelkeder 5,8/7,2 mm | Double kador strip 5,8/7,2 mm
- ▶ Hohlsaum-Schleusenstab mit 3 Klemmen | Sleeve pole and 3 clamps
- ▶ 3 Klettbandschlaufen für Dachreling | 3 touch fastener roof bar attachment tabs
- ▶ 3 extra breite 5 cm Quick Fix Dachbänder | 3 extra wide 5 cm quick fix roof bands
- ▶ Abnehmbarer Keder mittels RV ermöglicht leichtes An- und Abdocken am Fahrzeug | Drive away zip system
- ▶ Schleuse mit 2 Eingängen | Rear porch with 2 entries
- ▶ Aufrollbare Schleuse | Roll away attachment tunnel

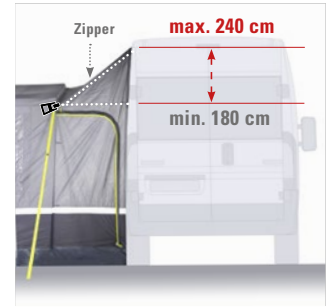

- ▶ Doppelkeder | Double kador strip
- ▶ Hohlsaum-Schleusenstab | Sleeve pole



- ▶ 3 Klettbandschlaufen für Dachreling | 3 touch fastener roof bar attachment tabs



- ▶ Abnehmbarer Keder mittels RV: leichtes An-/Abdocken | Drive away zip system



- ▶ 3 extra breite 5 cm Quick Fix Dachbänder | 3 extra wide 5 cm quick fix roof bands



# Pavillons | Mehrzweckzelte

## Pavilions | Utility tents

### ZIELGRUPPE | TARGET GROUP

Camping – Festival – Garten | Backyard

### EIGENSCHAFTEN | PERFORMANCE

Individueller Einsatz – freistehend – Stehhöhe |  
Individual use – self-supporting – stand-up height

### Pavillons | Pavilions

#### AUSSTATTUNG | FEATURES

- ▶ Wasserdicht | Waterproof
- ▶ Steilwand Konstruktion für optimalen Raumnutzen |  
Straight walls offer great space
- ▶ Aufrollbare Seitenwände | Roll away side walls
- ▶ Lampenhalter | Lamp holder

#### PREMIUM AUSSTATTUNG | PREMIUM FEATURES

- ▶ Teilbare Veranda Front komplett zu öffnen |  
Divisible roll away veranda front fully to open
- ▶ Gazefenster mit RV- Abdeckklappen |  
Mesh window with zipped cover
- ▶ Klarsichtfolienfenster mit Gardinen |  
Crystal clear window with curtain
- ▶ 4 abnehmbare Sicherheits-Sturmbänder |  
4 detachable safety storm bands
- ▶ Faulstreifen | Mudflap

### Mehrzweckzelte | Utility tents

#### AUSSTATTUNG | FEATURES

- ▶ Wasserdicht |  
Waterproof
- ▶ Ventilation |  
Ventilation

#### PREMIUM AUSSTATTUNG | PREMIUM FEATURES

- ▶ Zeltboden |  
Ground sheet
- ▶ Gazefenster mit RV-Abdeckklappe |  
Mesh window with zipped cover

Stahl-Fiberglas Gestänge  
mit ABS Winkel |  
Steel-fiberglass  
with ABS angles

Strapazierfähiges Qualitäts-Polyester 2000 mm,  
versiegelte Nähte, wasserdicht |  
Durable quality-polyester 2000 mm,  
seam sealed, waterproof



Gazefenster mit  
RV Abdeckung |  
Mesh window  
with zipped cover

Faulstreifen | Mudflap

Klarsichtfolien-Fenster  
mit Abdeckung |  
Crystal clear window  
with cover

Abnehmbare Sicherheits-Sturmbänder |  
Detachable safety storm bands

Teilbare Veranda Front komplett zu öffnen |  
Divisible roll away front fully to open

150 D Hypertex Polyester, extrem widerstandsfähig  
3000 mm, Nähte versiegelt, wasserdicht |  
150 D Hypertex Polyester, extreme durable 3000 mm,  
seam sealed, waterproof

Dauerlüftung |  
Permanent ventilation

Hochwertiges Stahl-Fiberglas  
Gestänge mit ABS Winkel |  
High grade steel-fiberglass  
frame with ABS angles

Gazefenster mit  
RV Abdeckung |  
Mesh window  
with zipped cover

Klarsichtfolien Fenster  
mit RV Abdeckung |  
Crystal clear window  
with zipped cover

Ebener Eingang |  
Level entrance



Eingenähter Zeltboden |  
Sewn-in ground sheet

## PAVILLON

Freistehender Pavillon |  
Self supporting pavilion

- ▶ Hellgrau-dunkelgrau-lime |  
Light grey-dark grey-lime
- ▶ 190T Polyester PU, 2000 mm
- ▶ Fiberglass 11 mm
- ▶ Stahl | Steel 16 mm ABS Winkel | Angle
- ▶ SBS Marken Reißverschluss |  
SBS brand zipper
- ▶ Reißverschluss Tragetasche |  
Zipped carry bag
- ▶ Extra starke 5 mm Erdnägel und V Heringe |  
Durable, strong 5 mm pegs and V pegs

## Ausstattung | Features

- ▶ 2 Reißverschluss Gazewände mit Stoff-Verstärkungsband |  
2 zipped mesh walls with fabric reinforcement strip
- ▶ 2 eingenähte Stoff Wände | 2 sewn-in fabric walls
- ▶ Anti Mosquito Boden-PVC Gazestreifen | Anti mosquito PVC ground mesh strip
- ▶ Gestänge Kennzeichnung | Coded frame
- ▶ Lampenhalter | Lamp holder



## PAVILLON

Art.-Nr./No. 14047 | EAN 4001690140478 | VPE/PU 1

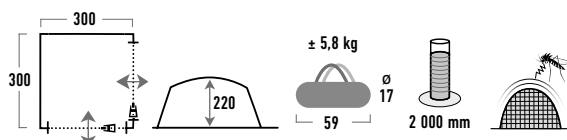

# CABANA

## Freistehender Pavillon | Self supporting pavilion

- ▶ Hellgrau-dunkelgrau-lime |  
Light grey-dark grey-lime
- ▶ 190T Polyester PU 2000 mm,  
nahtversiegelt | Seam taped
- ▶ Polyethylen Faulstreifen |  
Polyethylene mud flap
- ▶ Fiberglass 12,7 mm
- ▶ Stahl | Steel 19 mm ABS Winkel | Angle
- ▶ SBS Marken Reißverschluss #8/5 |  
SBS brand zipper #8/5
- ▶ Reißverschluss Tragetasche |  
Zipped carry bag

## Ausstattung | Features

- ▶ Teilbare Veranda Front komplett zu öffnen |  
Divisible roll away veranda front fully to open
- ▶ Klarsichtfolien-Fenster mit Abdeckung |  
Crystal clear window with cover
- ▶ 2 Gazefenster mit RV Abdeckung |  
2 mesh windows with zipped cover
- ▶ Dauerventilation | Permanent ventilation
- ▶ Faulstreifen | Mud flap
- ▶ 4 abnehmbare Sicherheits-Sturmbänder |  
4 detachable safety storm bands
- ▶ Lampenhalter | Lamp holder



## CABANA

Art.-Nr./No. **14052** | EAN **4001690140522** | VPE/PU 1

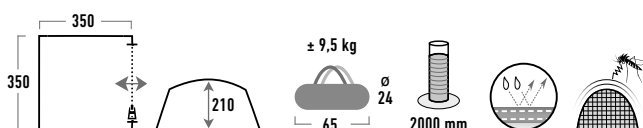

# TORBOLE

## Freistehendes Mehrzweckzelt | Self supporting utility tent

- ▶ Hellgrau-schwarz-blau | Light grey-black-blue
- ▶ 190T Polyester PU
- ▶ PE Boden | Groundsheet
- ▶ Fiberglass 11,0 / 9,5 mm
- ▶ Extra starke 5 mm Erdnägel-V-Heringe |  
Durable strong 5 mm pegs-V-peg
- ▶ SBS Marken Reißverschluss |  
SBS brand zipper
- ▶ Reißverschluss Tragetasche |  
Zipped carry bag

- ▶ Einhängbarer Zelt-Wannenboden | Linked in tube floor
- ▶ Wannenboden am Eingang herunterklappbar |  
Tub floor at entrance with fold down system
- ▶ Lichtquellenfenster im Dachbereich | Sky view window
- ▶ 2 Hochentlüftungen | 2 top ventilation's
- ▶ Dauerventilation mit RV Abdeckklappe und Abspannfunktion |  
Permanent ventilation with zipped cover and guy out function
- ▶ Solar Shower Haken. Max. Belastung 10,0 kg |  
Solar shower hook. Max. 10.0 kg
- ▶ Innentaschen | Inner pockets
- ▶ Lampenhalter | Lamp holder
- ▶ Trockenleine | Dry cord



## TORBOLE

Art.-Nr./No. **14014** | EAN **4001690140140** | VPE/PU 2

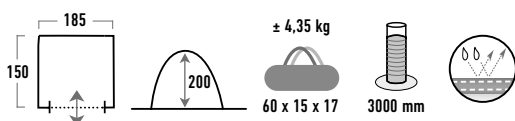



**RIMINI**

- ▶ Freistehend | Self supporting
- ▶ Organizer

**Pop Up Mehrzweckzelt |  
Pop up utility tent**

- ▶ Blau | Blue
- ▶ 190T Polyester
- ▶ Pop Up Federstahl | Steel wire
- ▶ SBS Marken Reißverschluss |  
SBS brand zipper
- ▶ Reißverschluss Tragetasche |  
Zipped carry bag



**RIMINI**

Art.-Nr./No. **14023** | EAN **4001690140232** | VPE/PU **6**

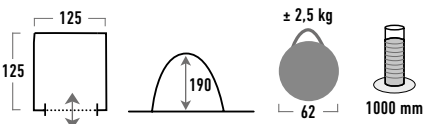

## LIDO

**Freistehendes Mehrzweckzelt |**  
**Self supporting Multi function tent**

- ▶ Hellgrau-dunkelgrau-blau |  
Light grey-dark grey-blue
- ▶ 190T Polyester
- ▶ Fiberglass 11 + 9,5 mm
- ▶ SBS Marken Reißverschluss |  
SBS brand zipper

- ▶ Hochentlüftung | Top ventilation
- ▶ Faulstreifen | Mudflap
- ▶ Solar Shower Haken. Max. Belastung 10,0 kg |  
Solar shower hook. Max. 10.0 kg
- ▶ Innentaschen | Inner pockets
- ▶ Trockenleine |  
Dry cord

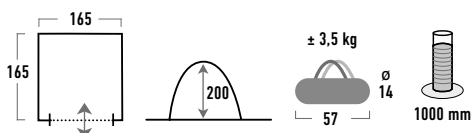

## LIDO

 Art.-Nr./No. **14012** | EAN **4001690140126** | VPE/PU **4**

# MISTRAL

## Windschutz | Wind screen

- ▶ Hellgrau-dunkelgrau-blau | Light grey-dark grey-blue
- ▶ 190T Polyester
- ▶ Stahl | Steel 16 mm
- ▶ Inkl. Abspannleinen und Heringe |  
Including guy ropes and pegs
  
- ▶ Lichtquellenstreifen |  
Crystal clear lightness stripe
- ▶ Leichter Aufbau durch vier Stahlgestänge |  
Easy set up with four steel poles



## MISTRAL

Art.-Nr./No. **10015** | EAN **4001690100151** | VPE/PU **6**

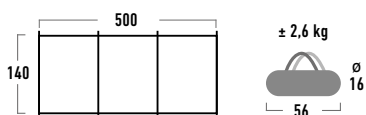

# VENETO

## Freistehendes Gerätezelt | Self supporting storage tent

- ▶ Hellgrau-dunkelgrau-blau | Light grey-dark grey-blue
- ▶ 150D HYPERTEX Polyester PU
- ▶ Fiberglass 11 mm -  
Stahl | Steel 19 mm ABS Winkel | Angle
- ▶ SBS Marken Reißverschluss |  
SBS brand zipper
- ▶ Packsack | Stuff sac

- ▶ Eingenähter Zeltboden | Fully sewn-in ground sheet
- ▶ Bodenwanne am Eingang mittels Reißverschluss herunterklappbar |  
Ground sheet at door can be fold down by zipper
- ▶ 2 Klarsichtfolien-Fenster mit Abdeckung |  
2 crystal clear windows with cover
- ▶ Gazefenster | Mesh window
- ▶ 2 Dauerventilationen mit Abstandshalter |  
2 permanent ventilations with distance holder
- ▶ Lampenhalter | Lamp holder



## VENETO

Art.-Nr./No. **14026** | EAN **4001690140263** | VPE/PU 1

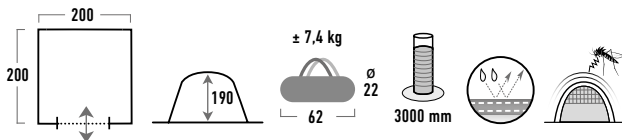

# MULTITENT

## Freistehendes Gerätezelt | Self supporting storage tent

- ▶ Hellgrau-dunkelgrau-blau | Light grey-dark grey-blue
- ▶ 300D PVC - 150D HYPERTEX Polyester PU
- ▶ Stahlgestänge | Steel frame 22 mm / 19 mm
- ▶ SBS Marken Reißverschluss |  
SBS brand zipper
- ▶ 150D Oxford Packsack |  
150D Oxford suff sac

- ▶ Herausnehmbarer PE Boden | Detachable PE ground sheet
- ▶ PE Faulstreifen | PE mudflap
- ▶ 2 Hochentlüfter | 2 top ventilations
- ▶ 4 Sturmspanngurten | 4 webbing storm straps



# MULTITENT

Art.-Nr./No. **14041** | EAN **4001690140416** | VPE/PU **1**

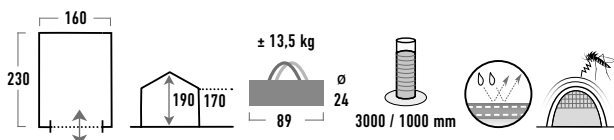

## TARP

## Sonnensegel | Tarp

- ▶ Grau | Grey
- ▶ 190T Polyester
- ▶ 2 Stahlstangen |  
2 steel poles 200 cm x diam. 22 mm
- ▶ 10 extra starke 5 mm Erdnägeln |  
10 durable, strong 5 mm pin pegs
- ▶ Reißverschluß Tragetasche  
mit Einleger |  
Zipped carrybag  
with insert sheet

- ▶ 8 verstärkte Ösen |  
8 reinforced eyelets
- ▶ 10 Abspannleinen |  
10 guy lines
- ▶ Umlaufband zur Verstärkung |  
Reinforced binding

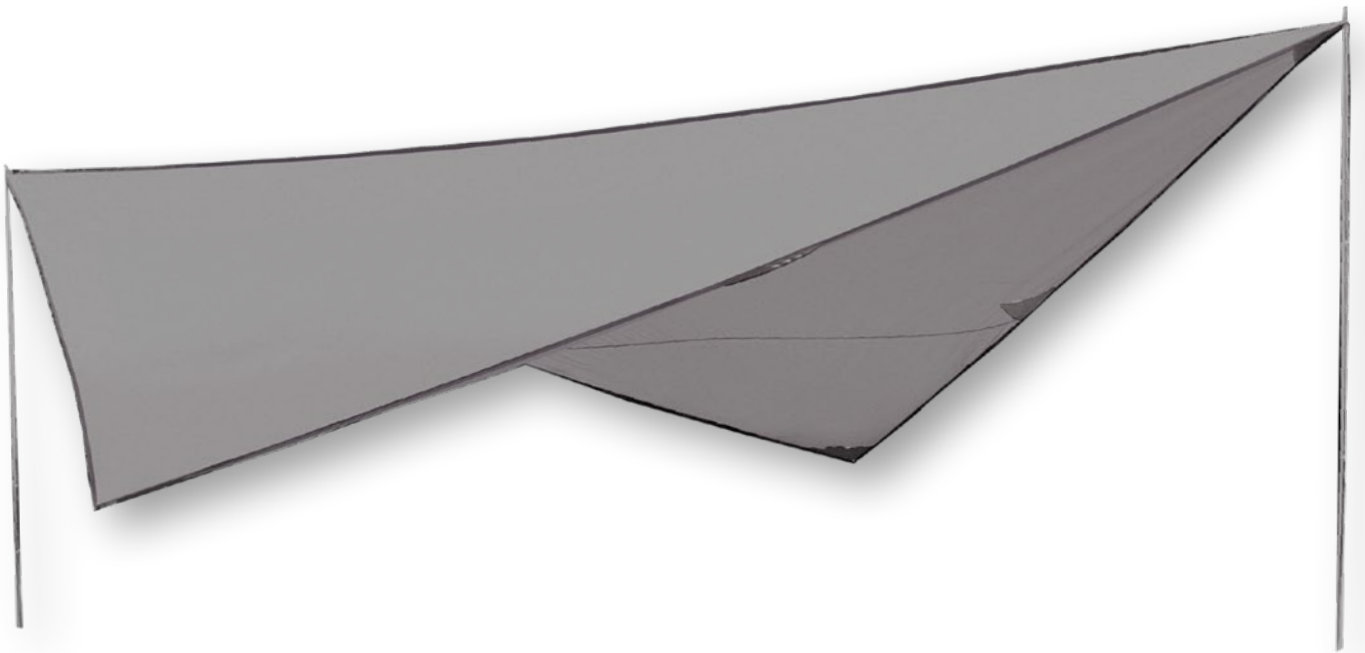

## TARP SIZE 1

Art.-Nr./No. **10031** | EAN **4001690100311** | VPE/PU 4

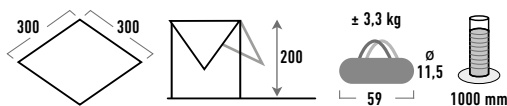

## TARP SIZE 2

Art.-Nr./No. **10034** | EAN **4001690100342** | VPE/PU 4

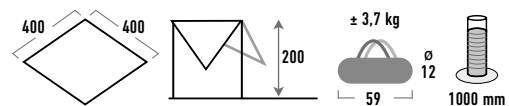

# CAPRI 3.0

## Sonnensegel | Tarp

- ▶ Aluminium-dunkelgrau | Aluminium-dark grey
- ▶ 190T Polyester Alu / PU 1000 mm
- ▶ 2 Stahlstangen | 2 steel poles 180 cm x 16 mm
- ▶ 10 extra starke 5 mm Erdnägel | 10 durable, strong 5 mm pin pegs
- ▶ Reißverschluss Tragetasche | Zipped carrybag

- ▶ 8 verstärkte Ösen | 8 reinforced eyelets
- ▶ 10 Abspannleinen | 10 guyropes
- ▶ Umlaufband zur Verstärkung | Reinforced binding
- ▶ Material auf der Innenseite Aluminium beschichtet | Fabric alu coated on the inside
- ▶ UV 80 Schutz | UV 80 protection (UV Standard 801)



## CAPRI 3.0

Art.-Nr./No. **10119** | EAN **4001690101196** | VPE/PU 4

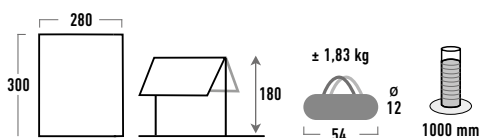

# Strandschutz

## Beach Shelter

### ZIELGRUPPE | TARGET GROUP

Strand |  
Beach

### EIGENSCHAFTEN | PERFORMANCE

Schneller Aufbau – freistehend |  
Quick set up – self supporting

### AUSSTATTUNG | FEATURES

- ▶ UV Schutzfaktor 40 Standard  
AS/NZ 4399:1996 | UV Protection 40 standard  
AS/NZ 4399:1996
- ▶ Gazeflächen |  
Mesh panels
- ▶ Boden mit Sandtaschen |  
Ground sheet with sand pockets

### PREMIUM AUSSTATTUNG | PREMIUM FEATURES

- ▶ UV Schutzfaktor 80 Standard 801 |  
UV Protection 80 standard 801
- ▶ Wärmereduzierende Aluminiumbeschichtung |  
Heat-reducing aluminium coating
- ▶ Hochwertige ABS Heringe |  
High grade ABS pegs



Standard AS/NZS 4399:1996



www.uvstandard801.com  
**UV STANDARD 801**  
18.1.10.0165-80-1 Hohenstein



Polyester PU UV 40



Standard AS/NZS 4399:1996



Große Gazeflächen |  
Large mesh panels

Flexibles Pop up  
Fiberglasgestänge |  
Flexible Pop up  
fiberglass poles

Sandtaschen |  
Sand pockets

Stabile ABS Heringe |  
Strong ABS pegs



Polyester, Innenseite  
Aluminium Beschichtung,  
Hitze Reflektor |  
Polyester, inside  
aluminium coating,  
heat reflection



Große Gazeflächen |  
Large mesh panels

Flexible Fiberglasgestänge |  
Flexible fiberglass poles

Sandtaschen |  
Sand pockets

Innentaschen |  
Inside pockets

# RAPID BEACH 80

## Schnellaufbau Strandmuschel | Quick Set up beach shelter

- ▶ Aluminium-dunkelgrau | Aluminium-dark grey
- ▶ 190T Polyester Alu / PU
- ▶ Kunststoff Erdnägel | Plastic pin pegs
- ▶ Fiberglass 7,9 mm



www.arnoldjubil.com  
UV STANDARD 801  
16.110.0105-00-1 Hochseide

- ▶ Freistehend | Self supporting
- ▶ Vier Sandtaschen | Four sand pockets
- ▶ Gut sichtbare Abspannlinien | High visible guyropes
- ▶ Gazeflächen gegen Hitzestau | Mesh panels against heat accumulation
- ▶ Abdeckklappen für Gazeflächen | Cover for mesh panels
- ▶ Material auf der Innenseite Aluminium beschichtet | fabric alu coated on the inside
- ▶ UV 80 Schutz | UV 80 protection (UV Standard 801)
- ▶ Schneller Aufbau durch einseitig geschlossene Gestängekanäle | Quick setup with the one side closed pole tunnel



## RAPID BEACH 80

Art.-Nr./No. **10139** | EAN **4001690101394** | VPE/PU 6

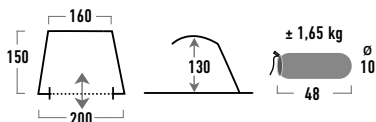

# CALIDA 80

## Regenschirm-System Strandmuschel | Umbrella system up beach shelter

- ▶ Aluminium-dunkelgrau | Aluminium-dark grey
- ▶ 190T Polyester Alu / PU
- ▶ Kunststoff Erdnägel | Plastic pin pegs
- ▶ Fiberglass 7,9 mm



- ▶ Freistehend | Self supporting
- ▶ Vier Sandtaschen | Four sand pockets
- ▶ Gut sichtbare Abspannleinen | High visible guyropes
- ▶ Gazeflächen gegen Hitzestau | Mesh panels against heat accumulation
- ▶ Abdeckklappen für Gazeflächen | Cover for mesh panels
- ▶ Material auf der Innenseite Aluminium beschichtet | Fabric alu coated on the inside
- ▶ UV 80 Schutz | UV 80 protection (UV Standard 801)
- ▶ Schneller Auf- und Abbau durch Regenschirm System | Quick setup and breakdown with the umbrella system



## CALIDA 80

Art.-Nr./No. **10138** | EAN **4001690101387** | VPE/PU **4**

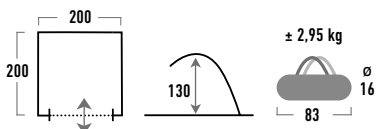

# CALOBRA 80

## Pop Up Strandmuschel | Pop up beach shelter

- ▶ Aluminium-dunkelgrau | Aluminium-dark grey
- ▶ 190T Polyester Alu / PU
- ▶ Kunststoff Erdnägel | Plastic pin pegs
- ▶ Fiberglass 5 mm



### CALOBRA 80 Art.-Nr./No. 10021 |

EAN 4001690100212 | VPE/PU 10

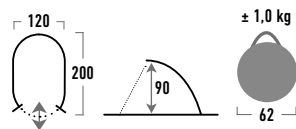

- ▶ Freistehend | Self supporting
- ▶ Vier Sandtaschen | Four sand pockets
- ▶ Gut sichtbare Abspannleinen | High visible guyropes
- ▶ Große Gazeflächen gegen Hitzestau | Large mesh panels against heat accumulation
- ▶ Material auf der Innenseite Aluminium beschichtet | Fabric alu coated on the inside
- ▶ UV 80 Schutz | UV 80 protection (UV Standard 801)
- ▶ Schneller Auf- und Abbau durch Pop up System | Fast setup and breakdown with the Pop up System



# CADIZ 80

## Strandmuschel | Beach shelter

- ▶ Aluminium-dunkelgrau | Aluminium-dark grey
- ▶ 190T Polyester Alu / PU
- ▶ Kunststoff Erdnägel | Plastic pin pegs
- ▶ Fiberglass 7,9 mm



### CADIZ 80 Art.-Nr./No. 10136 |

EAN 4001690101363 | VPE/PU 6

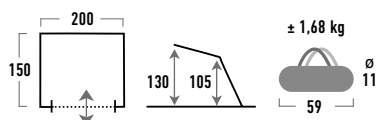

- ▶ Freistehend | Self supporting
- ▶ Vier Sandtaschen | Four sand pockets
- ▶ Gut sichtbare Abspannleinen | High visible guyropes
- ▶ Gazeflächen gegen Hitzestau | Mesh panels against heat accumulation
- ▶ Material auf der Innenseite Aluminium beschichtet | Fabric alu coated on the inside
- ▶ UV 80 Schutz | UV 80 protection (UV Standard 801)
- ▶ Leichter Aufbau durch markiertes Gestänge | Easy setup with color marked poles



# CORDOBA 80

## Strandmuschel | Beach shelter

- ▶ Aluminium-dunkelgrau | Aluminium-dark grey
- ▶ 190T Polyester Alu / PU
- ▶ Kunststoff Erdnägel | Plastic pin pegs
- ▶ Fiberglass 7,9 mm



**CORDOBA 80** Art.-Nr./No. **10137** |  
EAN **4001690101370** | VPE/PU 6

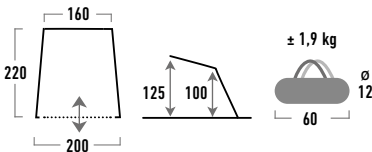

- ▶ Freistehend | Self supporting
- ▶ Vier Sandtaschen | Four sand pockets
- ▶ Gut sichtbare Abspannleinen | High visible guyropes
- ▶ Große Gazeflächen gegen Hitzestau und für 360° Rundumblick | Large mesh panels Against heat accumulation and for 360° view
- ▶ Extra großes Dach zur Beschattung | Extra large roof for shading
- ▶ Innentaschen | Organizer
- ▶ Material auf der Innenseite Aluminium beschichtet | Fabric alu coated on the inside
- ▶ UV 80 Schutz | UV 80 protection (UV Standard 801)
- ▶ Leichter Aufbau durch markiertes Gestänge | Easy setup with color marked poles

## UV-STANDARD 801 — UV-SCHUTZFAKTOR | UV PROTECTION



**UV STANDARD 801**  
18.1.10.0165-80-1 Hohenstein

Der UV-Schutzfaktor (UPF) gibt an, wieviel länger der Nutzer von Sonnenschutztextilien oder Beschattungssystemen sich in der Sonne aufhalten kann, ohne Hautschäden davonzutragen. Berechnungsgrundlage ist die so genannte Eigenschutzzeit der Haut, die allerdings je nach individuellem Hauttyp stark variiert. Beschattungssysteme die nach UV Standard 801 getestet werden, bieten sicheren Sonnenschutz, da Sie auch im nassen, gedehnten und gebrauchten Zustand getestet werden.

Ein textiles Material, wie z. B. ein Langarm-T-Shirt mit UPF 80, kann die Verweildauer in der Sonne, ohne Hautschädigungen zu provozieren, um das 80-fache verlängern.

The UV protection factor (UPF) indicates how much longer the user of sunscreen textiles or shading systems can stay in the sun without risking skin damage.

The basis of calculation is the so-called self-protection time of the skin, which, however, varies greatly depending on the individual skin type.

Shading systems tested to UV standard 801 provide safe sun protection because they are also tested in wet, stretched and used condition.

A textile material, such for example, a long-sleeved T-shirt with UPF 80, can prolong the exposure time in the sun, without provoking skin damage, by 80 times.

# MALLORCA

## Strandmuschel | Beach shelter

- ▶ Blau-grau | Blue-grey
- ▶ 190T Polyester
- ▶ PE Boden | PE groundsheet
- ▶ Fiberglass 7,9 / 6,9 mm



Standard AS/NZS 4399:1996



- ▶ Freistehend | Self supporting
- ▶ Vier Sandtaschen | Four sand pockets
- ▶ Gaze Lüftungen | Mesh vents
- ▶ UV 40 Schutz | UV 40 protection (Standard AS/NZS 4399:1996)

## MALLORCA Art.-Nr./No. 10128 |

EAN 4001690101288 | VPE/PU 8

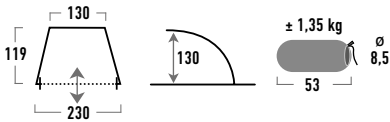

# BILBAO

## Strandmuschel | Beach shelter

- ▶ Blau-grau | Blue-grey
- ▶ 190T Polyester
- ▶ PE Boden | PE groundsheet
- ▶ Fiberglass 7,9 / 6,9 mm



Standard AS/NZS 4399:1996



- ▶ Freistehend | Self supporting
- ▶ Vier Sandtaschen | Four sand pockets
- ▶ Gaze Lüftungen | Mesh vents
- ▶ Innentaschen | Organizer
- ▶ Verschließbare Front mit Klettverschluss | Front with velcro closure
- ▶ UV 40 Schutz | UV 40 protection (Standard AS/NZS 4399:1996)

## BILBAO Art.-Nr./No. 10127 |

EAN 4001690101271 | VPE/PU 6

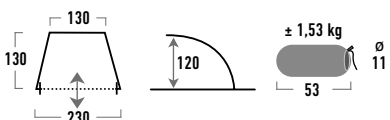

# CALVIA

## Pop Up Strandmuschel | Pop up beach shelter

- ▶ Blau-grau | Blue-grey
- ▶ 190T Polyester
- ▶ Fiberglass 5 mm



- ▶ Freistehend | Self supporting
- ▶ Vier Sandtaschen | Four sand pockets
- ▶ Große Gazeflächen gegen Hitzestau | Large mesh panels against heat accumulation
- ▶ UV 40 Schutz | UV 40 protection (Standard AS/NZS 4399:1996)
- ▶ Schneller Auf- und Abbau durch Pop up System | Fast setup and breakdown with the Pop up System



**CALVIA** Art.-Nr./No. **10124** |  
EAN **4001690101240** | VPE/PU **6**

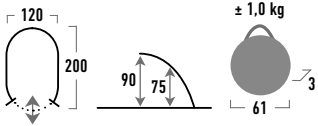

# SEVILLA

## Strandmuschel | Beach shelter

- ▶ Blau-grau | Blue-grey
- ▶ 190T Polyester
- ▶ Fiberglass 7,9 mm



- ▶ Freistehend | Self supporting
- ▶ Vier Sandtaschen | Four sand pockets
- ▶ Gazeflächen gegen Hitzestau | Mesh panels against heat accumulation
- ▶ Innentaschen | Organizer
- ▶ UV 40 Schutz | UV 40 protection (Standard AS/NZS 4399:1996)
- ▶ Leichter Aufbau durch markiertes Gestänge | Easy setup with color marked poles



**SEVILLA** Art.-Nr./No. **10129** |  
EAN **4001690101295** | VPE/PU **6**

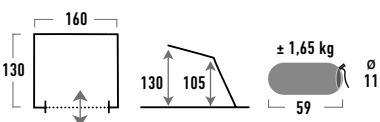

# Active Eco Line

## Schlafsäcke | Sleeping bags

Die High Peak Active ECO Line steht für:

- Recycelte Materialien
- Einhaltung ökologischer und sozialer Kriterien
- Umweltfreundliche Produktion der Materialien
- Schonung fossiler Ressourcen
- Nachhaltiges Chemiemangement

Die Active ECO Recycle Serie erfüllt folgende Kriterien:

**Außenbezug:** 100 % Polyester recycelt und „Global Standard Recycled“ zertifiziert. Die Materialien werden aus wiederaufbereiteten Fasern gewonnen. Wasser und schmutzabweisend mit BIONIC-FINISH®ECO ausgerüstet, eine umweltfreundliche und PFC freie Technologie.

**Innenbezug:** 100 % Polyester recycelt, „Global Standard Recycled“ zertifiziert. Die Materialien werden aus wiederaufbereiteten Fasern gewonnen. Atmungsaktiv und hautsympathisch.

**Füllungen:** 100 % Polyester, recycelt, „OEKO-TEX Standard 100“ zertifiziert. Die Materialien werden aus wiederaufbereiteten Fasern und rPET Flaschen gewonnen.



The High Peak Active ECO Line stands for:

- Recycled materials
- Compliance with ecological and social criteria
- Environmentally friendly production of materials
- Saving fossil resources
- Sustainable chemical management

The Active ECO Recycle series meet the following criteria:

**Shell:** 100 % Polyester recycled and “Global Standard Recycled” certified. The materials are obtained from post-consumer filaments. Water and dirt-repellent equipped with BIONIC-FINISH®ECO, an environmentally friendly and PFC-free technology.

**Lining:** 100 % Polyester recycled, “Global Standard Recycled” certified. The materials are obtained from post-consumer filaments. Breathable and skin-friendly.

**Filling:** 100 % Polyester, recycled, »OEKO-TEX Standard 100“ certified. The materials are obtained from post-consumer filaments and rPET bottles.



**ZIELGRUPPE | TARGET GROUP**

Aktives Camping, Rucksacktouren,  
Sommertrekking, Wandern und Reisen |  
Active camping, backpacking,  
summer trekking, hiking and travel

**EIGENSCHAFTEN | FEATURES**

Leichtgewicht, Kompakt, Funktional |  
Lightweight, compact, functional

**EINSATZBEREICH | APPLICATION**

Frühjahr / Sommer  
Temperatur Limit bis +3 °C EN ISO-23537-1:2016 |  
Spring / summer  
temperature limit to +3 °C EN ISO-23537-1:2016

Füllung 100 % Polyester recycelt |  
Filling 100 % Polyester recycled

Außenbezug recycelt, wasser- und schmutzabweisend  
PFC-freie Ausrüstung |  
Outer shell recycled, water and dirt-repellent  
PFC-free finish

Innenfutter, recycelt, atmungsaktiv |  
Lining, recycled, breathable



Reißverschluss-Abdeckleiste  
mit Einkemmschutz |  
Zip baffle with anti snag guard

Verstellbare Kontur-Kapuze |  
Adjustable shaped hood

Zwei-Wege Auto Lock Reißverschluss |  
Two way auto lock zipper



**PAK 600 ECO**

**PAK 1000 ECO**

**BLACK ARROW ECO**

**ULTRA PAK 500 ECO**

# PAK 600 ECO

Art.-Nr./No. **23247** | EAN **4001690232470** |  
VPE/PU **6**

## Leichtgewicht Mumien Schlafsack | Lightweight mummy sleeping bag

- ▶ Grün-rot | Green-red
- ▶ Außenbezug | Shell: 210T Polyester Rip Stop, recycelt | recycled, Rudolf Bionic Finish Eco
- ▶ Innenbezug | Lining: 240T Silk Polyester, atmungsaktiv, recycelt | breathable, recycled

BIONIC  
FINISH®ECO



### Füllung | Filling

- ▶ Dura Loft Density Polyester, recycelt | recycled, OEKO-TEX Standard 100
- ▶ Lagen System (thermisch versiegelt) | Layer system (Heat bonded)
- ▶ Oben | Top: 1 x 60 g/m<sup>2</sup>
- ▶ Boden | Bottom: 1 x 60 g/m<sup>2</sup>
- ▶ Füllgewicht | Filling weight: ca. | Appr. 210 g

### Steppung | Stitching

- ▶ Oben: Diagonale | Diagonal
- ▶ Boden: Loser Bezug | Loose cover
- ▶ 3 D Kapuze, verstellbar | 3 D hood, adjustable
- ▶ Reißverschluss Wärmeleiste | Zip baffle
- ▶ Auto-Lock Zwei-Wege Reißverschluss links | Auto lock two way zipper, left
- ▶ Reißverschluss-Einklemmschutz | Anti snag guard
- ▶ Fußteil mit Reißverschluss | Foot part with zipper
- ▶ RV-Schieber mit ergonomischer Griffmulde | Ergonomic shaped zip puller
- ▶ Windstopper am Reißverschluss-Ende | Windstopper at zipper end
- ▶ Innentasche | Inside pocket
- ▶ 150D Polyester Kompressions-Packsack, wasserabweisend, recycelt, PFC frei | 150D Polyester compression packsack, water repellent, recycled, PFC free

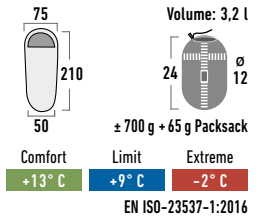

**Dura Loft®**  
DENSITY



# PAK 1000 ECO

Art.-Nr./No. **23251** | EAN **4001690232517** |  
VPE/PU 6

## Leichtgewicht Mumien Schlafsack | Lightweight mummy sleeping bag

- ▶ Grün-rot | Green-red
- ▶ Außenbezug | Shell: 210T Polyester Rip Stop, recycelt | recycled, Rudolf Bionic Finish Eco
- ▶ Innenbezug | Lining: 240T Silk Polyester, atmungsaktiv, recycelt | breathable, recycled

BIONIC  
FINISH®ECO



### Füllung | Filling

- ▶ Dura Loft Density Polyester, recycelt | recycled, OEKO-TEX Standard 100
- ▶ Lagen System (thermisch versiegelt) | Layer system (Heat bonded)
- ▶ Oben | Top: 1 x 150 g/m<sup>2</sup>
- ▶ Boden | Bottom: 1 x 120 g/m<sup>2</sup>
- ▶ Füllgewicht | Filling weight: ca. | Appr. 450 g

### Steppung | Stitching

- ▶ Oben: Diagonale | Diagonal
- ▶ Boden: Loser Bezug | Loose cover
- ▶ 3 D Kapuze, verstellbar | 3 D hood, adjustable
- ▶ Reißverschluss Wärmeleiste | Zip baffle
- ▶ Auto-Lock Zwei-Wege Reißverschluss links | Auto lock two way zipper, left
- ▶ Reißverschluss-Einklemmschutz | Anti snag guard
- ▶ Fußteil mit Reißverschluss | Foot part with zipper
- ▶ RV-Schieber mit ergonomischer Griffmulde | Ergonomic shaped zip puller
- ▶ Windstopper am Reißverschluss-Ende | Windstopper at zipper end
- ▶ Innentasche | Inside pocket
- ▶ 150D Polyester Kompressions-Packsack, wasserabweisend, recycelt, PFC frei | 150D Polyester compression packsack, water repellent, recycled, PFC free

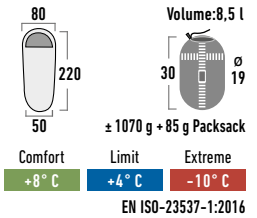

**Dura Loft®**  
DENSITY



Video



# ULTRA PAK 500 ECO

Art.-Nr./No. **23254** | EAN **4001690232548** |  
VPE/PU **6**

## Ultra-Leichtgewicht Mumien Schlafsack | Ultra lightweight mummy sleeping bag

- ▶ Grün-rot | Green-red
- ▶ Außenbezug | Shell: 300 T Nylon Rip Stop, recycelt | recycled, Rudolf Bionic Finish Eco
- ▶ Innenbezug | Lining: 290 T Nylon Rip Stop, atmungsaktiv, recycelt | breathable, recycled

BIONIC  
FINISH®ECO



### Füllung | Filling

- ▶ Polyester OEKO-TEX®, recycled
- ▶ Lagen System (thermisch versiegelt) | Layer system (Heat bonded)
- ▶ Oben | Top: 1 x 60 g/m<sup>2</sup>
- ▶ Boden | Bottom: 1 x 60 g/m<sup>2</sup>
- ▶ Füllgewicht | Filling weight: ca. | Appr. 210 g

### Steppung | Stitching

- ▶ Oben: Loser Bezug | Loose cover
- ▶ Boden: Loser Bezug | Loose cover
- ▶ 3 D Kapuze, verstellbar | 3 D hood, adjustable
- ▶ Reißverschluss Wärmeleiste | Zip baffle
- ▶ Auto-Lock Zwei-Wege Reißverschluss links | Auto lock two way zipper, left
- ▶ Reißverschluss-Einklemmschutz | Anti snag guard
- ▶ Innentasche | Inside pocket
- ▶ 300 T Nylon Rip Stop Packsack | Stuff sac, recycelt, Rudolf Bionic Finish Eco | 300 T Nylon Rip Stop stuff sac, recycled, Rudolf Bionic Finish Eco

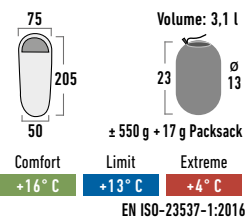

Video



# BLACK ARROW ECO

Art.-Nr./No. **23230** | EAN **4001690232302** |  
VPE/PU **6**

## Leichtgewicht Mumien Schlafsack | Lightweight mummy sleeping bag

- ▶ Grün-rot | Green-red
- ▶ Außenbezug | Shell: 210T Polyester recycelt | recycled, Rudolf Bionic Finish Eco
- ▶ Innenbezug | Lining: 190T Silk Polyester, atmungsaktiv, recycelt | breathable, recycled

BIONIC  
FINISH®ECO



### Füllung | Filling

- ▶ Dura Loft H1 Polyester, recycelt | recycled, OEKO-TEX Standard 100
- ▶ Lagen System (thermisch versiegelt) | Layer system (Heat bonded)
- ▶ Oben | Top: 2 x 90 g/m<sup>2</sup>
- ▶ Boden | Bottom: 2 x 90 g/m<sup>2</sup>
- ▶ Füllgewicht | Filling weight: ca. | Appr. 580 g

### Steppung | Stitching

- ▶ Oben: Diagonal | Diagonal
- ▶ Boden: Diagonal | Diagonal
- ▶ 3 D Kapuze, verstellbar | 3 D hood, adjustable
- ▶ Reißverschluss Wärmeleiste | Zip baffle
- ▶ Auto-Lock Zwei-Wege Reißverschluss links | Auto lock two way zipper, left
- ▶ Reißverschluss-Einklemmschutz | Anti snag guard
- ▶ Fußteil mit Reißverschluss | Foot part with zipper
- ▶ RV-Schieber mit ergonomischer Griffmulde | Ergonomic shaped zip puller
- ▶ Innentasche | Inside pocket
- ▶ 150D Polyester Kompressions-Packsack, recycelt, Rudolf Bionic Finish Eco | 150D Polyester compression packsack, recycled, Rudolf Bionic Finish Eco

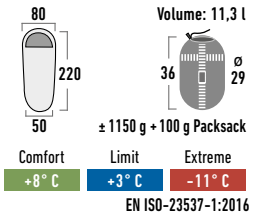

Dura Loft®  
H1



Video



# LITE PAK 800

Art.-Nr./No. **23260** | EAN **4001690232609** |  
VPE/PU **6**

## Leichtgewicht Mumien Schlafsack | Lightweight mummy sleeping bag

- ▶ Grün-rot | Green-red
- ▶ Außenbezug | Shell: 210T Polyester  
Rudolf Bionic Eco Finish
- ▶ Innenbezug | Lining: 185T Polyester  
atmungsaktiv | breathable

BIONIC  
FINISH®ECO



### Füllung | Filling

- ▶ Dura Loft H1
- ▶ Lagen System | Layer system
- ▶ Oben | Top: 1 x 150 g/m<sup>2</sup>
- ▶ Boden | Bottom: 1 x 150 g/m<sup>2</sup>
- ▶ Füllgewicht | Filling weight: ca. | Appr. 380 g

### Steppung | Stitching

- ▶ Oben: Loser Bezug | Loose cover
- ▶ Boden: Loser Bezug | Loose cover
- ▶ Verstellbare Kontur-Kapuze |  
Adjustable shaped hood
- ▶ Reißverschluss Wärmeleiste | Zip baffle
- ▶ Zwei-Wege Reißverschluss links | Two way zipper left
- ▶ Reißverschluss Einklemmschutz | Anti snag zipper guard
- ▶ RV-Schieber mit ergonomischer Griffmulde |  
Ergonomic shaped zip puller
- ▶ Innentasche | Inside pocket
- ▶ 150D Polyester Kompressions-Packsack |  
150 D polyester compression packsack

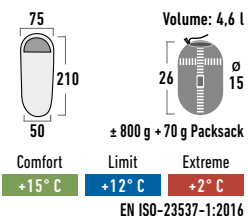

**Dura Loft®**  
**H1**



Video



# LITE PAK 1200

Art.-Nr./No. **23263** | EAN **4001690232630** |  
VPE/PU **6**

## Leichtgewicht Mumien Schlafsack | Lightweight mummy sleeping bag

- ▶ Grün-rot | Green-red
- ▶ Außenbezug | Shell: 210T Polyester  
Rudolf Bionic Eco Finish
- ▶ Innenbezug | Lining: 185T Polyester  
atmungsaktiv | breathable

BIONIC  
FINISH®ECO



### Füllung | Filling

- ▶ Dura Loft H1
- ▶ Lagen System | Layer system
- ▶ Oben | Top: 1 x 200 g/m<sup>2</sup>
- ▶ Boden | Bottom: 1 x 200 g/m<sup>2</sup>
- ▶ Füllgewicht | Filling weight: ca. | Appr. 600 g

### Stepung | Stitching

- ▶ Oben: Loser Bezug | Loose cover
- ▶ Boden: Loser Bezug | Loose cover
- ▶ Verstellbare Kontur-Kapuze |  
Adjustable shaped hood
- ▶ Reißverschluss Wärmeleiste | Zip baffle
- ▶ Zwei-Wege Reißverschluss links | Two way zipper left
- ▶ Reißverschluss Einklemmschutz | Anti snag zipper guard
- ▶ RV-Schieber mit ergonomischer Griffmulde |  
Ergonomic shaped zip puller
- ▶ Innentasche | Inside pocket
- ▶ 150D Polyester Kompressions-Packsack |  
150 D polyester compression packsack

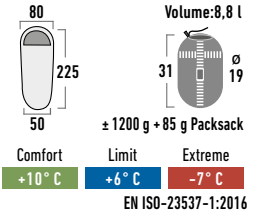

**Dura Loft®**  
H1



Video



# Performance Line

## Schlafsäcke | Sleeping bags

Die High Peak Performance Serie glänzt durch technische Innovationen, hohem Komfort und großem Einsatzbereich. Ausschließlich strapazierfähige, leichte Stoffe und hochwertige Dura Loft® Hightech Faserfüllungen mit besten Isolationseigenschaften werden für die Performance Serie verwendet.

Das enganliegende Kopfteil schützt den empfindlichen Kopf vor Kälte. Die funktionale Reißverschluss-Abdeckleiste mit Antiklemmschutz verhindert Kältebrücken und ein Verhaken des Reißverschlusses. Der Kompressionspacksack reduziert das Packvolumen.

High Peak setzt sich bewusst für ökologische Nachhaltigkeit ein und vermeidet den Einsatz von umweltschädlichen Perfluorcarbonen (PFC) bei wasserabweisenden Beschichtungen.

The High Peak Performance range stands for technical innovations, great comfort and a wide range of applications. Exclusively durable, lightweight fabrics and high-quality Dura Loft® innovative insulation fibres with high thermal capacity are used for the Performance range.

The adjustable 3 D hood design keeps the head and shoulder warmer during the night. High functionality with zip baffle reduces cold spots for optimal insulation and the zipper anti snag guard prevents the zip from snagging on the lining. The compression- sac reduces the packing to a minimum.

High Peak is consciously committed to ecological sustainability and avoids the use of environmentally harmful perfluorocarbon's (PFC) in water-repellent coatings.



TR 400

TR 350

TR 300

CENTURY 300

REDWOOD -3/-3L

HYPERION 1M/-5



**ZIELGRUPPE | TARGET GROUP**

Camping, Trekkingtouren,  
Bergtouren, Rucksacktouren |  
Camping, trekking,  
backpacking, mountain hiking

**EIGENSCHAFTEN | FEATURES**

Hohe Isolationswerte, aufwendige Konstruktionen,  
hervorragende Funktionalität |  
Excellent insulation performance,  
extensive constructions, top functionality

**EINSATZBEREICH | APPLICATION**

Frühjahr / Sommer / Herbst  
Temperatur Limit bis -6 ° C EN ISO-23537-1:2016 |  
Spring / summer / autumn  
temperature limit up to -6 ° C EN ISO-23537-1:2016

Außenbezug wasser- und schmutzabweisend  
PFC-freie Ausrüstung |  
Outer shell water and soil repellent  
PFC-free finish



Ergonomisch geformter  
Auto-Lock-Reißverschluss |  
Ergonomic shaped auto-lock zipper



Verstellbare Kontour-Kapuze |  
Adjustable shaped hood

Innenfutter, atmungsaktiv |  
Lining, breathable



Reißverschluss-Abdeckleiste |  
Zip baffle

Einklemmschutz |  
Anti snag guard



Ergonomisches Fußteil |  
Ergonomic foot box

# TR 400

Art.-Nr./No. **23115** | EAN **4001690231152** |  
VPE/PU **6**

## Mumien Schlafsack | Mummy sleeping bag

- ▶ Dunkelrot-grau | Dark red-grey
- ▶ Außenbezug | Shell: 210T Polyester, Rudolf Bionic Finish Eco
- ▶ Innenbezug | Lining: 190T Polyester atmungsaktiv | breathable

BIONIC  
FINISH®ECO



## Füllung | Filling

- ▶ Dura Loft H1 Polyester
- ▶ Lagen System | Layer system
- ▶ Oben | Top: 2 x 195 g/m<sup>2</sup>
- ▶ Boden | bottom: 2 x 175 g/m<sup>2</sup>
- ▶ Füllgewicht | Filling weight: ca. | Appr. 1125 g

## Steppung | Stitching

- ▶ Oben: Horizontal | Horizontal
- ▶ Boden: Horizontal | Horizontal
- ▶ Verstellbare Kontur-Kapuze | Adjustable shaped hood
- ▶ Wärmekragen (doppel), verstellbar | Shoulder baffle (double), adjustable
- ▶ Reißverschluss Wärmeleiste | Zip baffle
- ▶ Zwei-Wege Reißverschluss links | Two way zipper left
- ▶ Reißverschluss-Einklemmschutz | Anti snag guard
- ▶ RV-Schieber mit ergonomischer Griffmulde | Ergonomic shaped zip puller
- ▶ Innentasche | Inside pocket
- ▶ 150D Polyester Kompressions-Packsack | 150D Polyester compression packsack

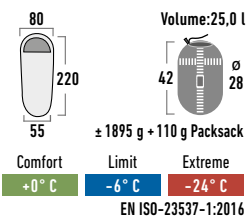

**Dura Loft®**  
H1



Video



# TR 350

Art.-Nr./No. **23068** | EAN **4001690230681** |  
VPE/PU 6

## Mumien Schlafsack | Mummy sleeping bag

- ▶ Dunkelrot-grau | Dark red-grey
- ▶ Außenbezug | Shell: 210T Polyester  
Rudolf Bionic Eco Finish
- ▶ Innenbezug | Lining: 190T Polyester  
atmungsaktiv | breathable

BIONIC  
FINISH®ECO



## Füllung | Filling

- ▶ Dura Loft H1
- ▶ Lagen System | Layer system
- ▶ Oben | Top: 2 x 175 g/m<sup>2</sup>
- ▶ Boden | bottom: 2 x 175 g/m<sup>2</sup>
- ▶ Füllgewicht | Filling weight: ca. | Appr. 1090 g

## Steppung | Stitching

- ▶ Oben: Horizontal | Horizontal
- ▶ Boden: Horizontal | Horizontal
- ▶ Verstellbare Kontur-Kapuze |  
Adjustable shaped hood
- ▶ Wärmekragen (doppel), verstellbar |  
Shoulder baffle (double), adjustable
- ▶ Reißverschluss Wärmeleiste | Zip baffle
- ▶ Zwei-Wege Reißverschluss links | Two way zipper left
- ▶ Reißverschluss-Einklemmschutz | Anti snag guard
- ▶ RV-Schieber mit ergonomischer Griffmulde |  
Ergonomic shaped zip puller
- ▶ Innentasche | Inside pocket
- ▶ 150D Polyester Kompressions-Packsack |  
150D Polyester compression packsack

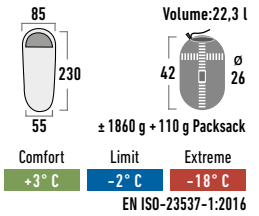

**Dura Loft®**  
H1



Video



# TR 300

## Mumien Schlafsack | Mummy sleeping bag

- ▶ Dunkelrot-grau | Dark red-grey
- ▶ Außenbezug | Shell: 210T Polyester Rudolf Bionic Finish Eco
- ▶ Innenbezug | Lining: 190T Polyester atmungsaktiv | breathable

BIONIC FINISH®ECO



### Füllung | Filling

- ▶ Dura Loft H1
- ▶ Lagen System | Layer system
- ▶ Oben | Top: 2 x 150 g/m<sup>2</sup>
- ▶ Boden | Bottom: 2 x 150 g/m<sup>2</sup>
- ▶ Füllgewicht | Filling weight: ca. | Appr. 950 g

### Steppung | Stitching

- ▶ Oben: Horizontal | Horizontal
- ▶ Boden: Horizontal | Horizontal
- ▶ Verstellbare Kontur-Kapuze | Adjustable shaped hood
- ▶ Wärmekragen (doppel), verstellbar | Shoulder baffle (double), adjustable
- ▶ Reißverschluss Wärmeleiste | Zip baffle
- ▶ Zwei-Wege Reißverschluss | Two way zipper
- ▶ Reißverschluss-Einklemmschutz | Anti snag guard
- ▶ RV-Schieber mit ergonomischer Griffmulde | Ergonomic shaped zip puller
- ▶ Innentasche | Inside pocket
- ▶ 150D Polyester Kompressions-Packsack | 150D Polyester compression packsack

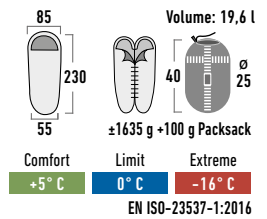

**Dura Loft®**  
H1



Video



## TR 300

Art.-Nr./No. **23066** | EAN **4001690230667** | VPE/PU **6**

- ▶ Zipper links | Left

## TR 300

Art.-Nr./No. **23061** | EAN **4001690230612** | VPE/PU **6**

- ▶ Zipper rechts | Right

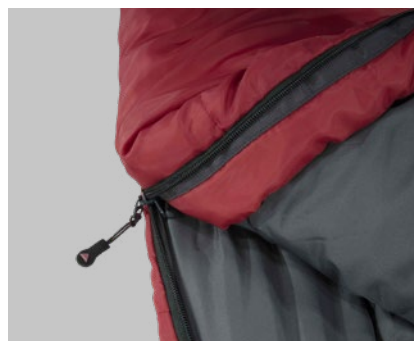

# CENTURY 300

Art.-Nr./No. **23227** | EAN **4001690232272** |  
VPE/PU 6

## Mumienschlafsack mit Mittelreißverschluss | Mummy sleeping bag with center zipper

- ▶ Dunkelrot-grau | Dark red-grey
- ▶ Außenbezug | Shell: 210T Polyester Rudolf Bionic Finish Eco
- ▶ Innenbezug | Lining: 190T Polyester atmungsaktiv | breathable

BIONIC  
FINISH® ECO



### Füllung | Filling

- ▶ Dura Loft H1
- ▶ Lagen System | Layer system
- ▶ Oben | Top: 1 x 300 g/m<sup>2</sup>
- ▶ Boden | Bottom: 1 x 300 g/m<sup>2</sup>
- ▶ Füllgewicht | Filling weight: ca. | Appr. 910 g

### Steppung | Stitching

- ▶ Oben: Horizontal | Horizontal
- ▶ Boden: Loser Bezug | Loose cover
- ▶ 3 D Kapuze, verstellbar | 3 D hood, adjustable
- ▶ Reißverschluss Wärmeleiste | Zip baffle
- ▶ Auto-Lock Zwei-Wege Reißverschluss mittig | auto lock two way zipper middle
- ▶ Reißverschluss-Einklemmschutz | Anti snag guard
- ▶ RV-Schieber mit ergonomischer Griffmulde | Ergonomic shaped zip puller
- ▶ Innentasche | Inside pocket
- ▶ 150D Polyester Kompressions-Packsack | 150D Polyester compression packsack

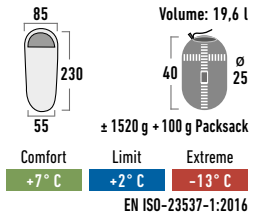

**Dura Loft®**  
H1



Video



# REDWOOD

## Mumien-Schlafsack | Mummy sleeping bag

- ▶ Dunkelrot-grau | Dark red-grey
- ▶ Außenbezug | Shell: 210T Polyester  
Rip Stop Druck | Print Rudolf Bionic Finish Eco
- ▶ Innenbezug | Lining: 190T Silk Polyester  
atmungsaktiv | breathable

BIONIC  
FINISH®ECO



### Füllung | Filling

- ▶ Dura Loft H4
- ▶ Lagen System | Layer system

### Steppung | Stitching

- ▶ Oben: Horizontal | Horizontal
- ▶ Boden: Horizontal | Horizontal
- ▶ 3 D Kapuze, verstellbar | 3 D hood, adjustable
- ▶ Wärmekragen (doppel), verstellbar | Shoulder baffle (double), adjustable
- ▶ Reißverschluss Wärmeleiste | Zip baffle
- ▶ Auto-Lock Zwei-Wege Reißverschluss links | Auto lock two way zipper, left
- ▶ RV-Schieber mit ergonomischer Griffmulde | Ergonomic shaped zip puller
- ▶ Fußteil mit Reißverschluss | Foot box with zipper
- ▶ Reißverschluss Einklemmschutz | anti snag guard
- ▶ Kissenfach | Pillow pocket
- ▶ Innentasche | Inside pocket
- ▶ 150D Polyester Kompressions-Packsack | 150D Polyester compression packsack



Video

**Dura Loft®**  
H4

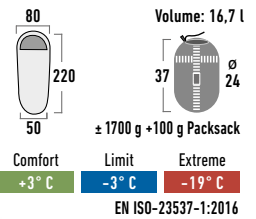

## REDWOOD -3

Art.-Nr./No. **23085** | EAN **4001690230858** |  
VPE/PU 6

### Füllung | Filling

- ▶ Oben | Top: 2 x 150 g/m<sup>2</sup>
- ▶ Boden | Bottom: 2 x 150 g/m<sup>2</sup>
- ▶ Füllgewicht | Filling weight: ca. | Appr. 870 g

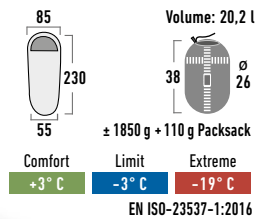

## REDWOOD -3 L

Art.-Nr./No. **23092** | EAN **4001690230926** |  
VPE/PU 6

### Füllung | Filling

- ▶ Oben | Top: 2 x 150 g/m<sup>2</sup>
- ▶ Boden | Bottom: 2 x 150 g/m<sup>2</sup>
- ▶ Füllgewicht | Filling weight: ca. | Appr. 940 g



# HYPERION

## Mumien-Schlafsack | Mummy sleeping bag

- ▶ Dunkelrot-grau | Dark red-grey
- ▶ Außenbezug | Shell: 255 T Nylon Rip Stop Rudolf Bionic Finish Eco
- ▶ Innenbezug | Lining: 255 T Nylon Rip Stop atmungsaktiv | breathable

BIONIC FINISH®ECO



### Füllung | Filling

- ▶ Dura Loft 3D Spiral
- ▶ Lagen System (thermisch versiegelt) | Layer system (heat bonded)



Video

### Steppung | Stitching

- ▶ Oben: Horizontal | Horizontal
- ▶ Boden: Loser Bezug | Loose cover
- ▶ 3 D Kapuze, verstellbar | 3 D hood, adjustable
- ▶ Wärmekragen (doppel), verstellbar | Shoulder baffle (double), adjustable
- ▶ 3 D Reißverschluss Wärmeleiste | 3 D zip baffle
- ▶ Auto-Lock Zwei-Wege Reißverschluss links | Auto lock two way zipper, left
- ▶ RV-Schieber mit ergonomischer Griffmulde | Ergonomic shaped zip puller
- ▶ Doppelter Reißverschluss-Einklemmschutz | Double anti snag guard
- ▶ Windstopper am Reißverschluss-Ende | Windstopper at zipper end
- ▶ Ergonomischer Fußteil | Ergonomic foot box
- ▶ Innentasche | Inside pocket
- ▶ 210D Polyester Kompressions-Packsack | 210D Polyester compression packsack

Dura Loft®  
3D SPIRAL

## HYPERION 1M

Art.-Nr./No. **23363** | EAN **4001690233637** | VPE/PU 4

### Füllung | Filling

- ▶ Oben | Top: 2 x 100 g/m<sup>2</sup>
- ▶ Boden | Bottom: 2 x 80 g/m<sup>2</sup>
- ▶ Füllgewicht | Filling weight: ca. | Appr. 700 g

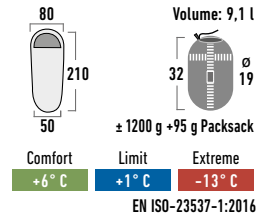

## HYPERION -5

Art.-Nr./No. **23373** | EAN **4001690233736** | VPE/PU 4

### Füllung | Filling

- ▶ Oben | Top: 2 x 150 g/m<sup>2</sup>
- ▶ Boden | Bottom: 2 x 130 g/m<sup>2</sup>
- ▶ Füllgewicht | Filling weight: ca. | Appr. 1250 g

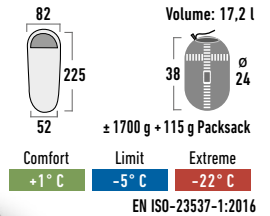

# Camping Line

## Schlafsäcke | Sleeping bags

Die High Peak Schlafsack Camping Serie mit optimalem Preis-Leistungs-Verhältnis. Ideal für Camping, Festival und den Besuch bei Freunden.

Die attraktiven Campingschlafsäcke sind mit der hochwertigen Dura Loft® H1 Füllung ausgestattet und bieten einen hohen Schlafkomfort und viel Bewegungsfreiheit.

High Peak setzt sich bewusst für ökologische Nachhaltigkeit ein und vermeidet den Einsatz von umweltschädlichen Perfluorcarbonen (PFC) bei wasserabweisenden Beschichtungen.

The High Peak sleeping bag camping range offers incredible value for money. Ideal for camping, festivals and occasional visiting friends.

The attractive camping sleeping bags are equipped with the high-grade Dura Loft® H1 filling and offer great sleeping comfort and plenty space for freedom of movement.

High Peak is consciously committed to ecological sustainability and avoids the use of environmentally harmful perfluorocarbon's (PFC) in water-repellent coatings.



EASY TRAVEL

ACTION 250

RANGER

PATROL

CEDUNA

CEDUNA DUO



**ZIELGRUPPE | TARGET GROUP**

Camping, Festivals, Freizeit-Camper |  
Camping, festival, free time camper

**EIGENSCHAFTEN | FEATURES**

Viel Platz für mehr Bewegungsfreiheit, Komfort |  
Extra space for greater freedom of movement, comfort

**EINSATZBEREICH | APPLICATION**

**Deckenschlafsäcke:** Sommer /  
Temperatur Limit bis +14 °C EN ISO 23537-1:2016 |  
**Square shaped sleeping bags:** Summer /  
temperature limit up to +14 °C EN ISO 23537-1:2016

Extra langer Zwei-Wege  
Reißverschluss bis zum Fußend |  
Extra long two-way zip around foot

Doppel-Decken-Funktion |  
Double-blanket-function



Polyester Außenbezug  
wasser- und schmutzabweisend -  
PFC-freie Ausrüstung |  
Polyester shell water and soil  
repellent - PFC-free finish

Polyester Innenfutter, atmungsaktiv |  
Polyester lining, breathable

**EINSATZBEREICH | APPLICATION**

**Mumenschlafsäcke:** Frühjahr / Sommer /  
Temperatur Limit Comfort bis +5 °C EN ISO-23537-1:2016 |  
**Mummy shaped sleeping bags:** Spring / summer /  
Temperature limit comfort up to +5 °C EN ISO-23537-1:2016

Polyester Außenbezug wasser- und schmutzabweisend - PFC-freie Ausrüstung  
Polyester shell water and soil repellent - PFC-free finish



Reißverschluss-Abdeckleiste |  
Zip baffle

Polyester Innenfutter, atmungsaktiv |  
Polyester lining, breathable



Verstellbares Kopfteil |  
Adjustable hood



Zwei-Wege-Reißverschluss |  
Two-way zipper

# EASY TRAVEL

Art.-Nr./No. **20090** | EAN **4001690200905** |  
VPE/PU **6**

## Trapez Schlafsack mit Kapuze | Trapeze shaped sleeping bag with hood

- ▶ Blau-dunkelblau | Blue-dark blue
- ▶ Außenbezug | Shell:  
210T Polyester  
Rudolf Bionic Finish Eco
- ▶ Innenbezug | Lining:  
185T Polyester  
atmungsaktiv | breathable

BIONIC  
FINISH®ECO



### Füllung | Filling

- ▶ Dura Loft H1
- ▶ Lagen System | Layer system
- ▶ Oben | Top: 1 x 150 g/m<sup>2</sup>
- ▶ Boden | Bottom: 1 x 150 g/m<sup>2</sup>
- ▶ Füllgewicht | Filling weight: ca. | Appr. 420 g

### Steppung | Stitching

- ▶ Oben: Wellen | Top: Wave
- ▶ Boden: Wellen | Top: Wave
- ▶ Verstellbare Kapuze | Adjustable hood
- ▶ Reißverschluss Wärmeleiste | Zip baffle
- ▶ Zwei-Wege Reißverschluss links | Two way zipper left
- ▶ Fußteil mit Reißverschluss | Foot part with zipper
- ▶ RV-Schieber mit ergonomischer Griffmulde | Ergonomic shaped zip puller
- ▶ Innentasche | Inside pocket
- ▶ 210T Polyester Packsack | 210T Polyester stuff sac

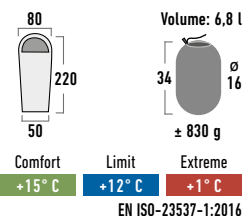

**Dura Loft®**  
H1



Video



# ACTION 250

Art.-Nr./No. **20086** | EAN **4001690200868** |  
VPE/PU 6

## Mumien-Schlafsack | Mummy sleeping bag

- ▶ Blau-dunkelblau | Blue-dark blue
- ▶ Außenbezug | Shell:  
210T Polyester  
Rudolf Bionic Finish Eco
- ▶ Innenbezug | Lining:  
185T Polyester  
atmungsaktiv | breathable

BIONIC  
FINISH®ECO



## Füllung | Filling

- ▶ Dura Loft H1
- ▶ Lagen System | Layer system
- ▶ Oben | Top: 1 x 250 g/m<sup>2</sup>
- ▶ Boden | Bottom: 1 x 250 g/m<sup>2</sup>
- ▶ Füllgewicht | Filling weight: ca. | Appr. 750 g

## Steppung | Stitching

- ▶ Oben: Wellen | Top: Wave
- ▶ Boden: Wellen | Top: Wave
- ▶ Verstellbare Kapuze | Adjustable hood
- ▶ Reißverschluss Wärmeleiste | Zip baffle
- ▶ Zwei-Wege Reißverschluss links | Two way zipper left
- ▶ RV-Schieber mit ergonomischer Griffmulde | Ergonomic shaped zip puller
- ▶ Innentasche | Inside pocket
- ▶ 210T Polyester Packsack | 210T Polyester stuff sac

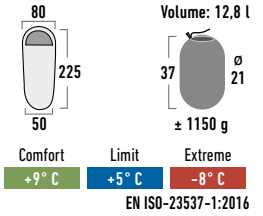

**Dura Loft®**  
H1



Video



# RANGER

Art.-Nr./No. **20034** | EAN **4001690200349** |  
VPE/PU **6**

## Deckenschlafsack | Square shaped sleeping bag

- ▶ Blau-dunkelblau | Blue-dark blue
- ▶ Außenbezug | Shell: 210T Polyester Rudolf Bionic Finish Eco
- ▶ Innenbezug | Lining: 185T Polyester atmungsaktiv | breathable

BIONIC  
FINISH®ECO



### Füllung | Filling

- ▶ Dura Loft H1
- ▶ Lagen System | Layer system
- ▶ Oben | Top: 1 x 200 g/m<sup>2</sup>
- ▶ Boden | Bottom: 1 x 200 g/m<sup>2</sup>
- ▶ Füllgewicht | Filling weight: ca. | Appr. 550 g

### Steppung | Stitching

- ▶ Oben: Rauten | Top: Diamond
- ▶ Boden: Rauten | Top: Diamond
- ▶ Zwei-Wege Reißverschluss links | Two way zipper left
- ▶ RV-Schieber mit ergonomischer Griffmulde | Ergonomic shaped zip puller
- ▶ Innentasche | Inside pocket
- ▶ 210T Polyester Packsack | 210T Polyester stuff sac

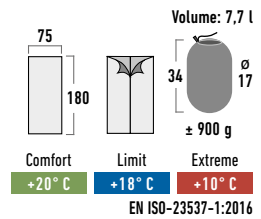

**Dura Loft®**  
H1



Video



# PATROL

Art.-Nr./No. **20037** | EAN **4001690200370** |  
VPE/PU **6**

## Deckenschlafsack | Square shaped sleeping bag

- ▶ Blau-dunkelblau | Blue-dark blue
- ▶ Außenbezug | Shell: 210T Polyester Rudolf Bionic Finish Eco
- ▶ Innenbezug | Lining: 185T Polyester atmungsaktiv | breathable

BIONIC  
FINISH®ECO



### Füllung | Filling

- ▶ Dura Loft H1
- ▶ Lagen System | Layer system
- ▶ Oben | Top: 1 x 200 g/m<sup>2</sup>
- ▶ Boden | Bottom: 1 x 200 g/m<sup>2</sup>
- ▶ Füllgewicht | Filling weight: ca. | Appr. 600 g

### Steppung | Stitching

- ▶ Oben: Rauten | Top: Diamond
- ▶ Boden: Rauten | Top: Diamond
- ▶ Zwei-Wege Reißverschluss links | Two way zipper left
- ▶ RV-Schieber mit ergonomischer Griffmulde | Ergonomic shaped zip puller
- ▶ Innentasche | Inside pocket
- ▶ 210T Polyester Packsack | 210T Polyester stuff sac

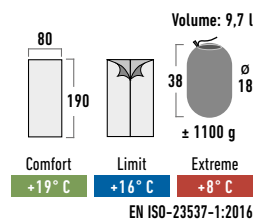

**Dura Loft®**  
H1



Video



# GEDUNA

Art.-Nr./No. **20030** | EAN **4001690200301** | VPE/PU 6

## Deckenschlafsack | Square shaped sleeping bag

- ▶ Blau-dunkelblau | Blue-dark blue
- ▶ Außenbezug | Shell: 210T Polyester Rudolf Bionic Finish Eco
- ▶ Innenbezug | Lining: 185T Polyester atmungsaktiv | breathable

BIONIC FINISH®ECO



### Füllung | Filling

- ▶ Dura Loft H1
- ▶ Lagen System | Layer system
- ▶ Oben | Top: 1 x 300 g/m<sup>2</sup>
- ▶ Boden | Bottom: 1 x 300 g/m<sup>2</sup>
- ▶ Füllgewicht | Filling weight: ca. | Appr. 950 g

### Steppung | Stitching

- ▶ Oben: Rauten | Top: Diamond
- ▶ Boden: Rauten | Top: Diamond
- ▶ Zwei-Wege Reißverschluss links | Two way zipper left
- ▶ RV-Schieber mit ergonomischer Griffmulde | Ergonomic shaped zip puller
- ▶ Innentasche | Inside pocket
- ▶ 210T Polyester Packsack | 210T Polyester stuff sac

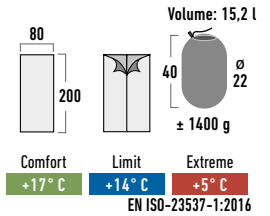

**Dura Loft®**  
H1



Video



# GEDUNA DUO

Art.-Nr./No. **20031** | EAN **4001690200318** | VPE/PU 4

## Doppel Deckenschlafsack | Double square shaped sleeping bag

- ▶ Blau-dunkelblau | Blue-dark blue
- ▶ Außenbezug | Shell: 210T Polyester Rudolf Bionic Finish Eco
- ▶ Innenbezug | Lining: 185T Polyester atmungsaktiv | breathable

BIONIC FINISH®ECO



### Füllung | Filling

- ▶ Dura Loft H1
- ▶ Lagen System | Layer system
- ▶ Oben | Top: 1 x 300 g/m<sup>2</sup>
- ▶ Boden | Bottom: 1 x 300 g/m<sup>2</sup>
- ▶ Füllgewicht | Filling weight: ca. | Appr. 1800 g

### Steppung | Stitching

- ▶ Oben: Rauten | Top: Diamond
- ▶ Boden: Rauten | Top: Diamond
- ▶ Zwei-Wege Reißverschluss | Two way zipper
- ▶ RV-Schieber mit ergonomischer Griffmulde | Ergonomic shaped zip puller
- ▶ Innentasche | Inside pocket
- ▶ 210T Polyester Packsack | 210T Polyester stuff sac

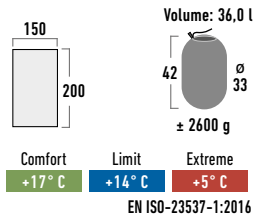

**Dura Loft®**  
H1



Video



## CONON 7

Art.-Nr./No. **21247** | EAN **4001690212472** |  
VPE/PU **6**

### Deckenschlafsack | Square shaped sleeping bag

- ▶ Grau-hellgrau | Grey-light grey
- ▶ Außenbezug | Shell: 65 % Polyester -  
35 % Baumwolle | Cotton
- ▶ Innenbezug | Lining: 65 % Polyester -  
35 % Baumwolle | Cotton

### Füllung | Filling

- ▶ Dura Loft H1
- ▶ Lagen System | Layer system
- ▶ Oben | Top: 1 x 200 g/m<sup>2</sup>
- ▶ Boden | Bottom: 1 x 200 g/m<sup>2</sup>
- ▶ Füllgewicht | Filling weight:  
ca. | Appr. 700 g



### Steppung | Stitching

- ▶ Oben: Horizontal | Horizontal
- ▶ Boden: Horizontal | Horizontal
- ▶ Verstellbare Kapuze | Adjustable hood
- ▶ Reißverschluss Wärmeleiste | Zip baffle
- ▶ Auto-Lock Zwei-Wege Reißverschluss links |  
Auto lock two way zipper, left
- ▶ Fußteil mit Reißverschluss | Foot part with zipper
- ▶ Reißverschluss-Einklemmschutz | Anti snag guard
- ▶ RV-Schieber mit ergonomischer Griffmulde | Ergonomic shaped zip puller
- ▶ Innentasche | Inside pocket
- ▶ Kompressions-Packsack 150D Oxford | Compression packsack 150D Oxford

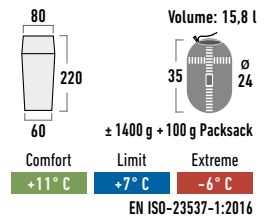

**Dura Loft®**  
H1



## DUNDEE 4

Art.-Nr./No. **21238** | EAN **4001690212380** |  
VPE/PU **2**

### Deckenschlafsack | Square shaped sleeping bag

- ▶ Grau-hellgrau | Grey-light grey
- ▶ Außenbezug | Shell:  
65 % Polyester -  
35 % Baumwolle | Cotton
- ▶ Innenbezug | Lining:  
65 % Polyester -  
35 % Baumwolle | Cotton

### Füllung | Filling

- ▶ Dura Loft H1
- ▶ Lagen System | Layer system
- ▶ Oben | Top: 1 x 300 g/m<sup>2</sup>
- ▶ Boden | Bottom: 1 x 300 g/m<sup>2</sup>
- ▶ Füllgewicht | Filling weight:  
ca. | Appr. 1160 g



### Steppung | Stitching

- ▶ Oben: Horizontal | Horizontal
- ▶ Boden: Loser Bezug | Loose cover
- ▶ Abnehmbare, vorgeformte Kapuze, verstellbar und extra  
aufgepolstert | Zip off, adjustable shaped hood with extra padding
- ▶ Reißverschluss Wärmeleiste | Zip baffle
- ▶ Auto-Lock Zwei-Wege Reißverschluss links |  
Auto lock two way zipper, left
- ▶ Fußteil mit Reißverschluss | Foot part with zipper
- ▶ Reißverschluss-Einklemmschutz | Anti snag guard
- ▶ RV-Schieber mit ergonomischer Griffmulde | Ergonomic shaped zip puller
- ▶ Innentasche | Inside pocket
- ▶ Kompressions-Packsack 150D Oxford | Compression packsack 150D Oxford

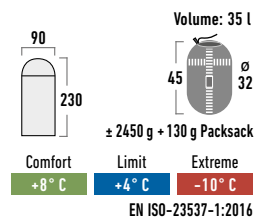

**Dura Loft®**  
H1



# TAY 8

Art.-Nr./No. **21229** | EAN **4001690212298** | VPE/PU 4

## Deckenschlafsack | Square shaped sleeping bag

- ▶ Grau-hellgrau | Grey-light grey
- ▶ Außenbezug | Shell: 65 % Polyester - 35 % Baumwolle | Cotton
- ▶ Innenbezug | Lining: 65 % Polyester - 35 % Baumwolle | Cotton

## Füllung | Filling

- ▶ Dura Loft H1
- ▶ Lagen System | Layer system
- ▶ Oben | Top: 1 x 300 g/m<sup>2</sup>
- ▶ Boden | Bottom: 1 x 300 g/m<sup>2</sup>
- ▶ Füllgewicht | Filling weight: ca. | Appr. 1200 g

## Steppung | Stitching

- ▶ Oben: Horizontal | Horizontal
- ▶ Boden: Horizontal | Horizontal
- ▶ Reißverschluss Wärmeleiste | Zip baffle
- ▶ Auto-Lock Zwei-Wege Reißverschluss links | Auto lock two way zipper, left
- ▶ Reißverschluss-Einklemmschutz | Anti snag guard
- ▶ RV-Schieber mit ergonomischer Griffmulde | Ergonomic shaped zip puller
- ▶ Innentasche | Inside pocket
- ▶ Kompressions-Packsack 150D Oxford | Compression packsack 150D Oxford

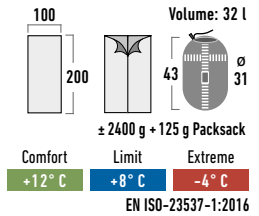

**Dura Loft®**  
H1



Video



## TEMPERATURANGABEN | TEMPERATURE RATING

Bitte betrachten Sie die Temperaturangaben der Schlafsackmodelle als Anhaltswerte. Kälte wird oft subjektiv unterschiedlich empfunden.

Temperature rating is an indication only and subject to the condition of the user.

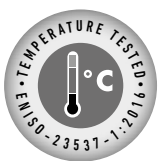

**EN ISO-23537-1:2016**

### EXTREMPERATUR

Unterer Extremwert der Temperatur, bei dem das Risiko von Gesundheitsschäden durch Hypothermie (Unterkühlung) besteht (bezogen auf eine Standard-Frau, 60 kg).

### EXTREME TEMPERATURE

Lower extreme temperature where there is the risk of a health damage by hypothermia (related to a „standard-woman“ with a body mass of 60 kg).

### GRENZTEMPERATUR

Untere Temperaturgrenze, bei welcher der vollständig in den Schlafsack eingepackte Schläfer in zusammengerollter Körperhaltung gerade noch nicht friert (bezogen auf einen Standard-Mann, 70 kg).

### LIMIT TEMPERATURE

Lower limit of the transition range down to which a sleeping person with a body mass of 70 kg („standard-man“) being completely packed into the sleeping bag with a rolled-up body posture is just not feeling cold.

### KOMFORTTEMPERATUR

Untere Grenze des Komforttemperaturbereichs, bis zu der ein vollständig in den Schlafsack eingepackter Schläfer in entspannter Körperhaltung, z.B. auf dem Rücken liegend, gerade noch nicht friert (bezogen auf eine Standard-Frau, 60 kg).

### COMFORT TEMPERATURE

Lower limit of the comfort range down to which a sleeping person with a body mass of 60 kg („standard woman“) being completely packed into the sleeping bag and lying relaxed on the back is just not feeling cold.

# IMPALA VARIO

Art.-Nr./No. **23044** | EAN **4001690230445** |  
VPE/PU **6**

## Kinder Mumien Schlafsack verlängerbar 135-165 cm | Junior mummy sleeping bag adjustable 135-165 cm

- ▶ Grün-lime | Green-lime
- ▶ Außenbezug | Shell:  
190T Polyester
- ▶ Innenbezug | Lining:  
190T Silk Polyester  
atmungsaktiv | breathable

BIONIC  
FINISH®ECO



### Füllung | Filling

- ▶ Dura Loft H1
- ▶ Lagen System | Layer system
- ▶ Oben | Top: 1 x 250 g/m<sup>2</sup>
- ▶ Boden | Bottom: 1 x 250 g/m<sup>2</sup>
- ▶ Füllgewicht | Filling weight: ca. | Appr. 450 g

### Steppung | Stitching

- ▶ Oben: Horizontal | Horizontal
- ▶ Boden: Horizontal | Horizontal
- ▶ Verlängerbar 135 -165 cm mittels Reißverschluss |  
Extendable 135-165 cm by zipper
- ▶ Zwei-Wege Reißverschluss links | Two way zipper left
- ▶ Reißverschluss Wärmeleiste | Zip baffle
- ▶ RV-Schieber mit ergonomischer Griffmulde | Ergonomic shaped zip puller
- ▶ Innentasche | Inside pocket
- ▶ Kompressions-Packsack 150D Oxford |  
Compression packsack 150D Oxford

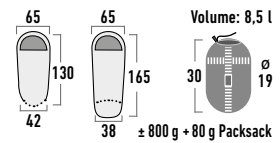

Komforttemperatur  
Comfort temperature

+12 °C

**Dura Loft®**  
H1



Video





# TEMBO VARIO

Art.-Nr./No. **23043** | EAN **4001690230438** |  
VPE/PU 6

## Kinder Mumien Schlafsack verlängerbar 155-185 cm | Junior mummy sleeping bag adjustable 155-185 cm

- ▶ Rot-blau | Red-blue
- ▶ Außenbezug | Shell:  
190T Polyester
- ▶ Innenbezug | Lining:  
190T Silk Polyester  
atmungsaktiv | breathable

BIONIC  
FINISH®ECO



### Füllung | Filling

- ▶ Dura Loft H1
- ▶ Lagen System | Layer system
- ▶ Oben | Top: 1 x 250 g/m<sup>2</sup>
- ▶ Boden | Bottom: 1 x 250 g/m<sup>2</sup>
- ▶ Füllgewicht | Filling weight: ca. | Appr. 570 g

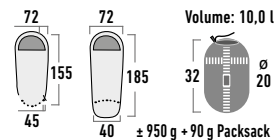

Komforttemperatur  
Comfort temperature

+12 °C

### Steppung | Stitching

- ▶ Oben: Horizontal | Horizontal
- ▶ Boden: Horizontal | Horizontal
- ▶ Verlängerbar 155-185 cm mittels Reißverschluss |  
Extendable 155-185 cm by zipper
- ▶ Zwei-Wege Reißverschluss links | Two way zipper left
- ▶ Reißverschluss Wärmeleiste | Zip baffle
- ▶ RV-Schieber mit ergonomischer Griffmulde | Ergonomic shaped zip puller
- ▶ Innentasche | Inside pocket
- ▶ Kompressions-Packsack 150D Oxford |  
Compression packsack 150D Oxford

**Dura Loft®**  
H1



Video



## COMOX

Art.-Nr./No. **23045** | EAN **4001690230452** |  
VPE/PU **6**

### Kinder Mumien Schlafsack | Junior mummy sleeping bag

- ▶ Hellblau-orange | Light blue-orange
- ▶ Außenbezug | Shell: 190T Polyester
- ▶ Innenbezug | Lining:  
190T Silk Polyester atmungsaktiv |  
breathable

BIONIC  
FINISH®ECO



### Füllung | Filling

- ▶ Dura Loft H1
- ▶ Lagen System | Layer system
- ▶ Oben | Top: 1 x 300 g/m<sup>2</sup>
- ▶ Boden | Bottom: 1 x 300 g/m<sup>2</sup>
- ▶ Füllgewicht | Filling weight: ca. | appr. 570 g

### Steppung | Stitching

- ▶ Oben: Horizontal | Horizontal
- ▶ Boden: Horizontal | Horizontal
- ▶ Vorgeformte Kapuze mit gelpolstertem Kordel Tunnel, verstellbar |  
Shaped hood with padded drawcord tunnel, adjustable
- ▶ Zwei-Wege Reißverschluss links | Two way zipper left
- ▶ Reißverschluss Wärmeleiste | Zip baffle
- ▶ Reißverschluss Einklemmschutz | Anti snag guard
- ▶ RV-Schieber mit ergonomischer Griffmulde |  
Ergonomic shaped zip puller
- ▶ Innentasche | Inside pocket
- ▶ Extra großer 150D Oxford Kompressions-Packsack |  
Oversized 150D compression Oxford Stuff sac

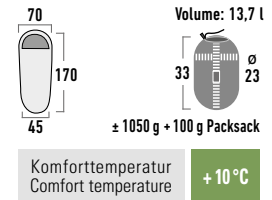

**Dura Loft®**  
**H1**



## Dura Loft®

- Beste Wärmeisolierung
- Isolieren auch noch in feuchtem Zustand
- Schnelltrocknend
- Silikonisiert
- Pflegeleicht
- Geeignet für Allergiker

- Highest thermal insulation
- Retention of insulating properties even when moist
- Fast drying
- Siliconized
- Low-maintenance
- Suitable for persons suffering from allergies

## Dura Loft® H1

Sehr robuste Füllung bestehend aus 2 Komponenten:

- 6D Hohlfaser zur optimalen Wärmespeicherung
- 6D Vollfaser zur Stabilisierung.

Dura Loft H1 verwenden wir für unsere „Camping Line“ und Einstieg „Active Eco Line“.

Highly durable filling consisting of 2 components:

- 6D hollow fiber for optimal heat retaining
- 6D full fiber for stabilization

We incorporate Dura Loft H1 in our “Camping Line” and entry level “Active Eco Line”.

## Dura Loft® H4

Hochbausch Füllung bestehend aus 2 Komponenten:

- 6D 4-Kanal- Hohlfaser zur optimalen Wärmespeicherung
- 6D Vollfaser zur Stabilisierung

Für beste Isolierung und Bausch Kraft (Loft). Unsere bestens bewährte Dura Loft H4 Faser Füllung wird für unsere „Performance Line“ eingesetzt.

Super loft filling consisting of 2 components:

- 6D 4- channel hollow fiber for optimal heat retaining
- 6D full fiber for stabilization

The 4 channel fiber offers the highest degree of insulation and optimum fill power (loft). Our truly proven Dura Loft H 4 filling is used for our “Performance Line”.

# BOOGIE

Art.-Nr./No. **23012** | EAN **4001690230124** |  
VPE/PU **6**

## Kinder Mumien Schlafsack | Junior mummy sleeping bag

- ▶ Blau-orange | Blue-orange
- ▶ Außenbezug | Shell: 170T Polyester
- ▶ Innenbezug | Lining:  
185T Polyester atmungsaktiv |  
breathable

BIONIC  
FINISH®ECO



### Füllung | Filling

- ▶ Dura Loft H1
- ▶ Lagen System | Layer system
- ▶ Oben | Top: 1 x 200 g/m<sup>2</sup>
- ▶ Boden | Bottom: 1 x 200 g/m<sup>2</sup>
- ▶ Füllgewicht | Filling weight: ca. | Appr. 480 g

### Steppung | Stitching

- ▶ Oben: S-Steppung | Top: S-stitching
- ▶ Boden: S-Steppung | Bottom: S-stitching
- ▶ Zwei-Wege Reißverschluss links |  
Two way zipper left
- ▶ Reißverschluss Wärmeleiste | Zip baffle
- ▶ RV-Schieber mit ergonomischer Griffmulde |  
Ergonomic shaped zip puller
- ▶ Innentasche | Inside pocket
- ▶ Packsack | Stuff sac

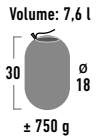
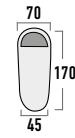

Komforttemperatur  
Comfort temperature

+14 °C

**Dura Loft®**  
H1



Video



**Dura Loft®**  
3D SPIRAL

Hochleistungs-Spiralfaser-Füllung, bestehend aus 4 Komponenten:

- 1,5D Spiral-Leichtgewicht-Vollfaser zur Gewichtsminimierung
- 3D Spiral-Hohlfaser zur optimalen Wärmespeicherung
- 3D Spiral-Vollfaser zur Stabilisierung
- 4D Vollfaser zur thermischen Versiegelung

Für beste Wärmeleistung und Haltbarkeit werden alle Komponenten thermisch versiegelt. Die spiralförmige Faser hat eine sehr hohe Rückstellkraft und entwickelt den ursprünglichen Loft sofort, nachdem der Schlafsack dem Packsack entnommen wird, in dem er zuvor stark komprimiert wurde. Dura Loft 3D Spiral wird ausschließlich für unsere Performance Serie Hyperion verwendet.

High-performance spiral fiber filling, consisting of 4 components:

- 1,5D spiral-lightweight full fiber for weight minimization
- 3D spiral hollow fiber for optimal heat retaining
- 3D spiral full fiber for stabilization
- 4D Full fiber for thermal sealing

All components are thermally sealed for highest thermal capacity and durability. The spiral-shaped fiber has a very high restoring force, restoring the original loft once the sleeping bag has been removed from the packsack, in which it had been highly compressed. Dura Loft 3D Spiral is exclusively used for our performance series Hyperion.

**Dura Loft®**  
DENSITY

Leichtgewicht Füllung aus 3 Komponenten:

- 0,78D Mikrofaser zur Gewichtsminimierung
- 3D Powerloft Vollfaser zur Stabilisierung und optimale Loft
- 4 D Vollfaser zur thermischen Versiegelung

Sehr leicht zu komprimieren für kleinstes Packmaß. Gutes Isolations-Gewichtsverhältnis. Die Füllung wird thermisch versiegelt. Dura Loft Density wird bei unseren „Active Eco Line“ PAK 600 ECO und PAK 1000 ECO eingesetzt.

Lightweight filling consisting of 3 components:

- 0,78D micro fiber for weight minimization
- 3D Powerloft full fiber for stabilization and optimum loft
- 4D Full fiber for thermal sealing

Very easy to compress to achieve smallest pack size possible. Good insulation – weight ratio. The filling is thermally sealed. Dura Loft Density is used for our “Active Eco Line” PAK 600 ECO and PAK 1000 ECO.

# NANUK

Art.-Nr./No. **23512** | EAN **4001690235129** | VPE/PU **2/12**

- ▶ Verstellbares Kopfteil | Adjustable hood
- ▶ Auto-Lock Zwei-Wege RV links | Two way zipper left
- ▶ 150D Oxford Packsack | 150D Oxford stuff sac

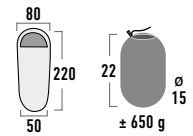

## Fleece Schlafsack | Fleece sleeping bag

- ▶ Schwarz | Black
- ▶ Anti Pilling Fleece 170 g/m<sup>2</sup>



# MARSALA

Art.-Nr./No. **23523** | EAN **4001690235235** | VPE/PU **4/12**

- ▶ Seitlicher Klettverschluss-Einstieg, links | Velcro attachments for side entry, left
- ▶ 210D Oxford Packsack | 210D Oxford stuff sac
- ▶ Banderolenverpackung mit Euro Lochung | Paper banderole packing with Euro perforation

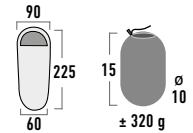

## Inlet für Mumenschlafsäcke | Inlet for mummy sleeping bags

- ▶ Grau | Grey
- ▶ 80 % Polyester - 20 % Baumwolle | Cotton



# AVOLA

Art.-Nr./No. **23527** | EAN **4001690235273** | VPE/PU **4/12**

- ▶ Kopfteil mit Kissenfach | Head rest with pillow pocket
- ▶ Beidseitiger Klettverschluss-Einstieg | Velcro attachments on both sides entry
- ▶ 210D Oxford Packsack | 210D Oxford stuff sac
- ▶ Banderolenverpackung mit Euro Lochung | Paper banderole packing with Euro perforation

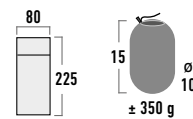

## Inlet für Deckenschlafsäcke | Inlet for squared shaped sleeping bags

- ▶ Grau | Grey
- ▶ 80 % Polyester - 20 % Baumwolle | Cotton



# ENNA

Art.-Nr./No. **23506** | EAN **4001690235068** | VPE/PU **4/12**

## Inlet für Mumienschlafsäcke | Inlet for mummy sleeping bags

- ▶ Blau | Blue
- ▶ 100 % Baumwolle | Cotton
- ▶ 78 g/m<sup>2</sup>



- ▶ Seitlicher Klettverschluß-Einstieg, links |  
Velcro attachments for side entry, left
- ▶ 210D Oxford Packsack | 210D Oxford stuff sac
- ▶ Banderolenverpackung mit Euro Lochung |  
Paper banderole packing with Euro perforation

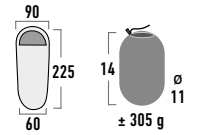

# MODICA

Art.-Nr./No. **23507** | EAN **4001690235075** | VPE/PU **4/12**

## Inlet für Deckenschlafsäcke | Inlet for squared shaped sleeping bags

- ▶ Blau | Blue
- ▶ 100 % Baumwolle | Cotton
- ▶ 78 g/m<sup>2</sup>



- ▶ Kopfteil mit Kissenfach |  
Head rest with pillow pocket
- ▶ Beidseitiger Klettverschluß-Einstieg |  
Velcro attachments on both sides entry
- ▶ 210D Oxford Packsack | 210D Oxford stuff sac
- ▶ Banderolenverpackung mit Euro Lochung |  
Paper banderole packing with Euro perforation

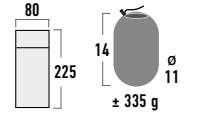

# LICATA

Art.-Nr./No. **23508** | EAN **4001690235082** | VPE/PU **4/12**

## Doppel-Inlet für Deckenschlafsäcke | Twin inlet for squared shaped sleeping bags

- ▶ Blau | Blue
- ▶ 100 % Baumwolle | Cotton
- ▶ 78 g/m<sup>2</sup>



- ▶ Kopfteil mit Kissenfach |  
Head rest with pillow pocket
- ▶ Beidseitiger Klettverschluß-Einstieg |  
Velcro attachments on both sides entry
- ▶ 210D Oxford Packsack | 210D Oxford stuff sac
- ▶ Banderolenverpackung mit Euro Lochung |  
Paper banderole packing with Euro perforation

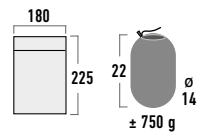

# OUTDOOR BLANKET

Art.-Nr./No. **23535** | EAN **4001690235358** | VPE/PU **2/12**

## Outdoor Decke mit wasserdichter Unterseite | Outdoor blanket, waterproof bottom sheet

- ▶ Grau-schwarz | Grey-black
- ▶ 450 g
- ▶ 120 x 150 cm

BIONIC FINISH®ECO



- ▶ Obermaterial | Top: 80 % Baumwolle | Cotton - 20 % Polyester
- ▶ Unterseite | Bottom: 210D Oxford PU 2000 mm
- ▶ 210D Packsack Polyester 18 x 12 cm | 210D polyester stuff sac 18 x 12 cm
- ▶ Outdoor Decke mit wasserdichter Unterseite | Outdoor blanket, waterproof bottom sheet
- ▶ 4 Schlaufen zur Befestigung mit Heringen | 4 loops for fixation with pegs
- ▶ Multi funktional | Multi functional

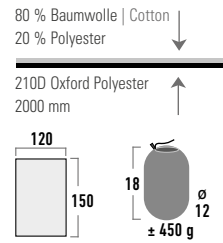

Unterseite | Bottom 2000 mm



# COZY BLANKET

Art.-Nr./No. **23537** | EAN **4001690235372** | VPE/PU **2/12**

## Outdoor Picknick Decke mit Isolierung | Outdoor blanket with isolation

- ▶ Blau-schwarz | Blue-black
- ▶ 660 g
- ▶ 150 x 180 cm

BIONIC FINISH®ECO



- ▶ Oberseite | Top: 190T Silk Polyester
- ▶ Unterseite | Bottom: 210D Oxford PU 2000 mm
- ▶ Füllung | Filling: 50 gr<sup>2</sup> Hohlfaser | Hollow fibre
- ▶ 210D Packsack Polyester 22 x 13 cm | 210D polyester stuff sac 22 x 13 cm
- ▶ Outdoor Picknick Decke mit Isolierung | Outdoor blanket with isolation
- ▶ Unterseite wasserdicht | Waterproof bottom sheet
- ▶ Multi funktional | Multi functional

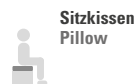
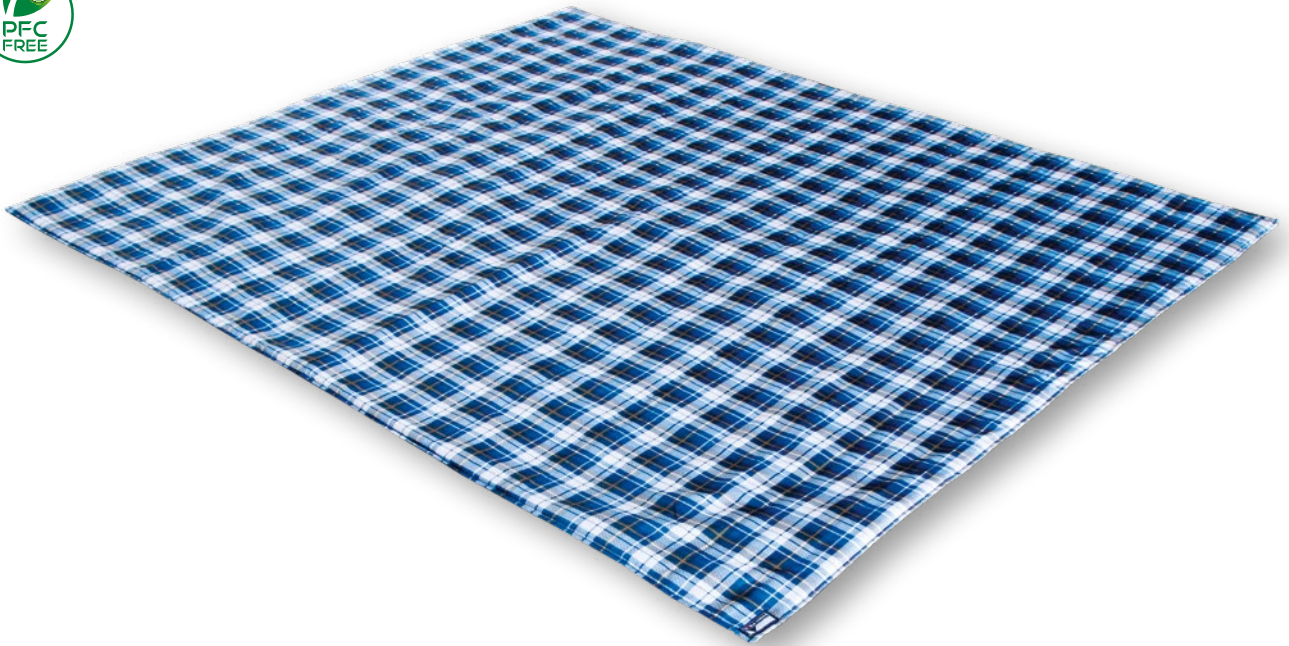
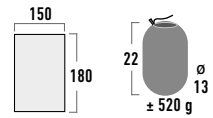
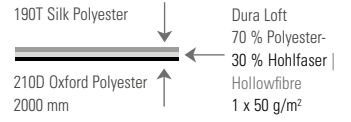

# DENVER

## Komfort Matratze extra lang & breit | Comfort mattress extra long & wide

▶ Citronelle | Citronelle

- ▶ 190T Polyester, gebürstet | brushed, Honeycomb Druck | Print  
PVC Laminat | Laminated 0,25 mm, anti slip
- ▶ 23 horizontale Luftkammern |  
23 horizontal air chambers
- ▶ 1 großes Ventil | 1 oversized pad-valve
- ▶ 150D Polyester Packsack | Stuff sac



# DENVER

Art.-Nr./No. **41027** | EAN **4001690410274** |  
VPE/PU **6**

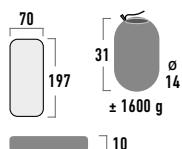

# DALLAS

## Komfort Matratze extra lang & breit | Comfort mattress extra long & wide

▶ Citronelle | Citronelle

- ▶ 190T Polyester, gebürstet | brushed, Honeycomb Druck | Print  
PVC Laminat | Laminated 0,25 mm, anti slip
- ▶ 23 horizontale Luftkammern |  
23 horizontal air chambers
- ▶ Integrierte Fußpumpe |  
Built in foot pump
- ▶ 1 großes Ventil | 1 oversized pad-valve
- ▶ 150D Polyester Packsack | Stuff sac



# DALLAS

Art.-Nr./No. **41032** | EAN **4001690410328** |  
VPE/PU **6**

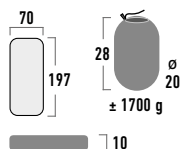



# DALLAS TWIN

## Doppel Komfort Matratze | Twin comfort mattress

- ▶ Citronelle | Citronelle

- ▶ 190T Polyester, gebürstet | brushed, Honeycomb Druck | Print PVC Laminat | Laminated 0,25 mm, anti slip
- ▶ 23 horizontale Luftkammern | 23 horizontal air chambers
- ▶ Integrierte Fußpumpe | Build in foot pump
- ▶ 1 großes Ventil | 1 oversized pad-valve
- ▶ 150D Polyester Packsack | Stuff sac

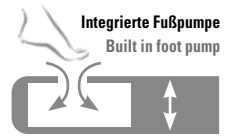

## DALLAS TWIN

Art.-Nr./No. **41033** | EAN **4001690410335** |  
VPE/PU **4**

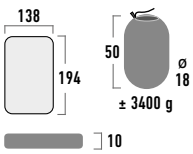

# TULSA

Art.-Nr./No. **41002** | EAN **4001690410021** | VPE/PU **2/10**

## Leichtgewicht Trekking-Matratze | Lightweight trekking mattress

- ▶ Dunkelgrau | Dark grey
- ▶ 190T Polyester · PVC Laminat 0,25 mm |  
PVC laminated 0,25 mm

- ▶ 6 separate Luftkammern | 6 separate air chambers
- ▶ 6 Sicherheitsventile | 2 safety valve
- ▶ 150D Polyester Packsack | 150D polyester stuff sac

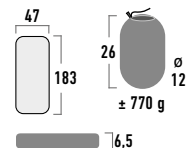

# TEXAS

Art.-Nr./No. **41003** | EAN **4001690410038** | VPE/PU **10**

## Leichtgewicht Trekking-Matratze | Lightweight trekking mattress

- ▶ Dunkelgrau | Dark grey
- ▶ 190T Polyester · PVC Laminat 0,25 mm |  
PVC laminated 0,25 mm

- ▶ 6 separate Luftkammern | 6 separate air chamber
- ▶ Integrierte Fußpumpe | Build in foot pump
- ▶ 1 Air Plug Ventil | 1 Air plug valve
- ▶ 1 Sicherheitsventil | 1 safety valve
- ▶ 150D Polyester Packsack | Stuff sac

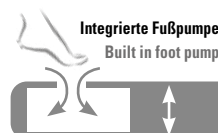
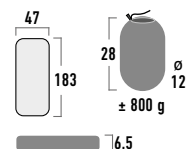

# DAYTON

Art.-Nr./No. **41006** | EAN **4001690410069** | VPE/PU **10**

## Leichtgewicht Komfort Matratze | Lightweight comfort mattress

- ▶ Dunkelgrau | Dark grey
- ▶ 190T Polyester · PVC Laminat 0,25 mm |  
PVC laminated 0,25 mm

- ▶ 23 horizontale Luftkammern | 23 horizontal air chambers
- ▶ Integrierte Fußpumpe | Built in foot pump
- ▶ 1 Air Plug Ventil | 1 Air plug valve
- ▶ 2 Sicherheitsventile | 2 safety valve
- ▶ 150D Polyester Packsack | 150D polyester stuff sac

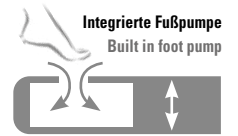
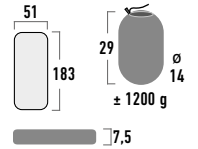

# DAYTON XL

Art.-Nr./No. **41007** | EAN **4001690410076** | VPE/PU **6**

## Komfort Matratze extra lang & breit | Comfort mattress extra long & wide

- ▶ Dunkelgrau | Dark grey
- ▶ 190T Polyester · PVC Laminat 0,25 mm |  
PVC laminated 0,25 mm

- ▶ 23 horizontale Luftkammern | 23 horizontal air chambers
- ▶ Integrierte Fußpumpe | Built in foot pump
- ▶ 1 Air Plug Ventil | 1 Air plug valve
- ▶ 2 Sicherheitsventile | 2 safety valve
- ▶ 150D Polyester Packsack | Stuff sac

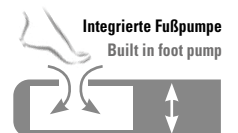
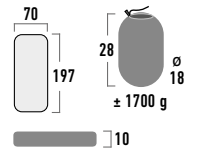

# MINTO

## Selbstaufblasbare Matte | Selfinflatable mat

- ▶ Schwarz | Black

- ▶ Oberseite | Top: 190T Polyester, gebürstet | Brushed, Honeycomb Druck | Print  
PVC Laminat | Laminated 0,25 mm, anti slip
- ▶ Boden | Bottom: 150D Polyester Oxford anti slip
- ▶ Hochverdichteter PU Schaum 19 kg/m<sup>3</sup> | High density foam 19 kg/m<sup>3</sup>
- ▶ »Wave Cut« gestanz | »Wave Cut« pattern
- ▶ Trapezform | Trapeze shape
- ▶ Kunststoff Schraubventil | Plastic screw valve
- ▶ 2 Spanngurte | 2 compression straps
- ▶ 150D Polyester Packsack | Stuff sac

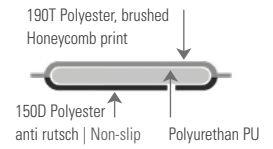

## MINTO M

Art.-Nr./No. **41115** |  
EAN **4001690411158** | VPE/PU 4

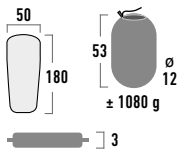

## MINTO L

Art.-Nr./No. **41116** |  
EAN **4001690411165** | VPE/PU 4

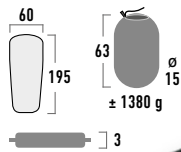

## MINTO XL

Art.-Nr./No. **41117** |  
EAN **4001690411172** | VPE/PU 4

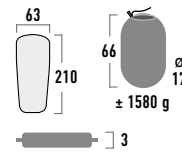

# OREGON

## Selbstaufblasbare Matte | Selfinflatable mat

- ▶ Citronelle | Citronelle

- ▶ Oberseite | Top: 190T Polyester, gebürstet | Brushed, Honeycomb Druck | Print  
PVC Laminat | Laminated 0,25 mm, anti slip
- ▶ Boden | Bottom: 150D Polyester Oxford anti slip
- ▶ Hochverdichteter PU Schaum 19 kg/m<sup>3</sup> | High density foam 19 kg/m<sup>3</sup>
- ▶ »Wave Cut« gestanzt | »Wave Cut« pattern
- ▶ Trapezform | Trapeze shape
- ▶ Flip Ventil | Flip valve
- ▶ 2 Spanngurte | 2 compression straps
- ▶ 150D Polyester Packsack | Stuff sac

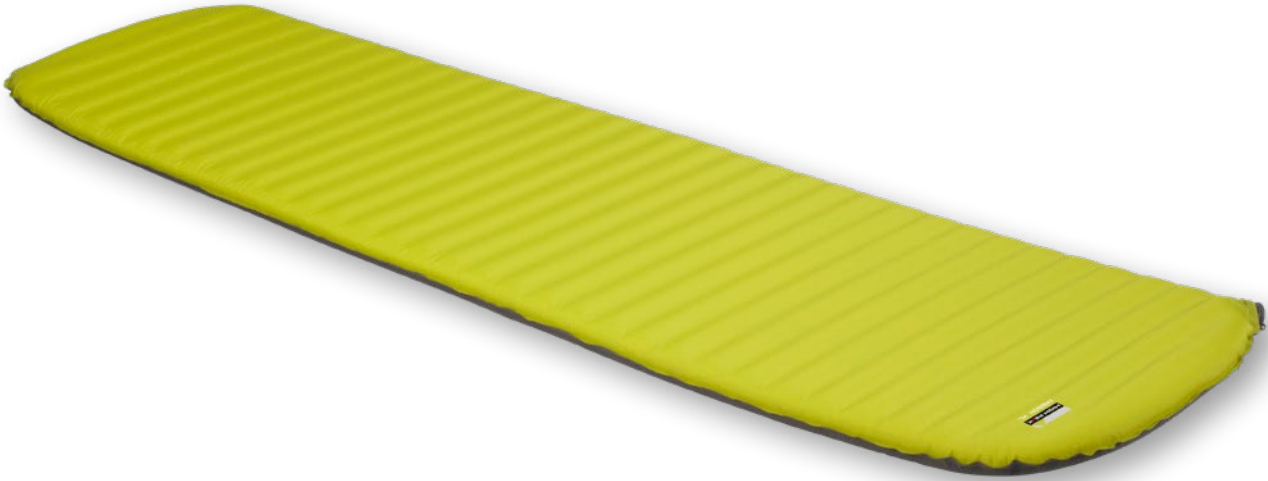
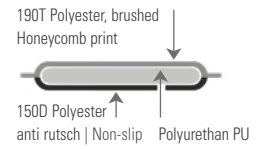

## OREGON M

Art.-Nr./No. **41124** |  
EAN **4001690411240** | VPE/PU 4

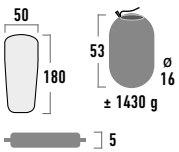

## OREGON L

Art.-Nr./No. **41125** |  
EAN **4001690411257** | VPE/PU 4

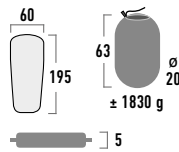

## OREGON XL

Art.-Nr./No. **41126** |  
EAN **4001690411264** | VPE/PU 4

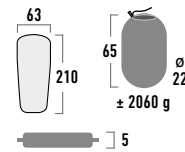

# KODIAK

## Selbstaufblasbare Matte | Selfinflatable mat

► Schwarz | Black

- Oberseite | Top: 190T Polyester, gebürstet | brushed, Honeycomb Druck | Print  
PVC Laminat | Laminated 0,25 mm, anti slip
- Boden | bottom: 150D Polyester Oxford anti slip
- Hochverdichteter PU Schaum 19 kg/m<sup>3</sup> | High density foam 19 kg/m<sup>3</sup>
- »Wave Cut« gestanzt | »Wave Cut« pattern
- Trapezform | Trapeze shape
- Flip Ventil | Flip valve
- 2 Spanngurte | 2 compression straps
- 150D Polyester Packsack | Stuff sac

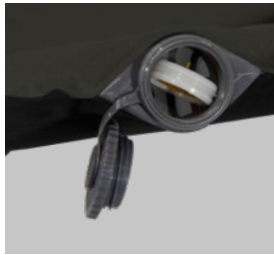
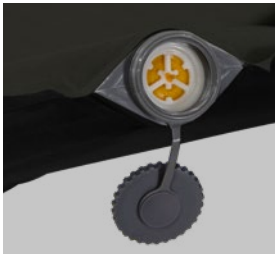
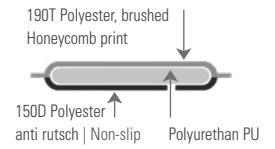

## KODIAK L

Art.-Nr./No. **41130** |  
EAN **4001690411301** | VPE/PU 2

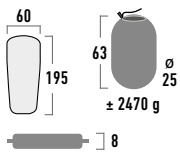

## KODIAK XL

Art.-Nr./No. **41131** |  
EAN **4001690411318** | VPE/PU 2

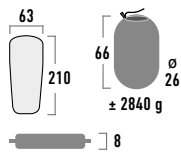

# INDIANA

## Selbstaufblasbare Matte | Selfinflatable mat

- ▶ Dunkelgrau | Dark grey

- ▶ 190T Polyester · PVC Laminat 0,25 mm |  
PVC laminated 0,25 mm
- ▶ Hochverdichteter PU Schaum 19 kg/m<sup>3</sup> |  
High density foam 19 kg/m<sup>3</sup>
- ▶ 11 x Punktverschweißst | 11 x spot welded
- ▶ 1 Kunststoff Ventil |  
1 Plastic valve
- ▶ 2 Spanngurte |  
2 compression straps
- ▶ 150D Polyester Packsack | Stuff sac



## INDIANA

Art.-Nr./No. **41020** |  
EAN **4001690410205** | VPE/PU 4

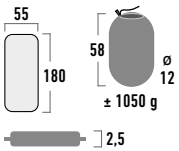

# SITZKISSEN

Art.-Nr./No. **41333** | EAN **4001690413336** | VPE/PU 20

## Sitzkissen | Pillow

- ▶ Schwarz | Black
- ▶ 40 x 30 x 3 cm

- ▶ Oberseite | Top: 190T Polyester, gebürstet | Brushed,  
Honeycomb Druck | Print  
PVC Laminat | Laminated 0,25 mm
- ▶ Boden | Bottom: 150D Polyester Oxford anti slip
- ▶ Hochverdichteter PU Schaum 19 kg/m<sup>3</sup> |  
High density foam 19 kg/m<sup>3</sup>
- ▶ 1 Kunststoff Ventil | 1 Plastic valve
- ▶ 150D Polyester Packsack | Stuff sac

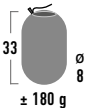
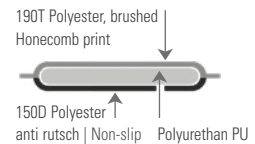

# CROSS-BEAM LUFTBETTEN | AIR BEDS

## Extra lange Luftbetten | Extra long air beds

- ▶ Hellgrau-blau | Light grey-blue
- ▶ Luftbetten, ideal für Camping und als Gästebett | Air beds for outdoor and indoor use
- ▶ Pflegeleicht und schmutzabweisend | Easy to clean and dirt repellent
- ▶ Mit integrierter Fußpumpe minutenschnell aufgeblasen | Inflated within minutes with built in pump
- ▶ Mit Schnellentlüftungsventil | Fast venting valve for easier deflation
- ▶ Auch mit externer Hand- oder Fußpumpe aufblasbar | Optional to inflate with hand or foot pump
- ▶ Oberfläche aus organischer Viskose für herrlichen Schlafkomfort | Soft organic viscose top offering incomparable comfort
- ▶ Technischer Honeycomb Druck auf der Oberfläche | Technical honeycomb print on top
- ▶ Cross-Beams für unvergesslichen Liegekomfort | Cross-Beams for unforgettable comfort
- ▶ Anti-Rutsch-Funktion für glatten Untergrund | Anti-skid function on smooth surface

### ANTI-RUTSCH-FUNKTION

durch spezielle Pads auf der Unterseite

### ANTI-SKID-FUNCTION

due to special pads on backside

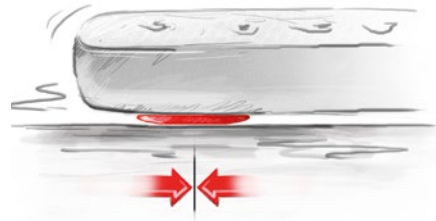

Video

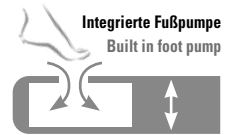

## CROSS-BEAM SINGLE

Art.-Nr./No. **40043** | EAN **4001690400435** | VPE/PU **3**

- ▶ 14 Luftkammern | Tubes
- ▶ Größe aufgeblasen | Size inflated ca. 195 x 75 x 20 cm
- ▶ Gewicht | Weight ca. 1,9 kg
- ▶ Belastbarkeit | Maximum load: 100 kg



## CROSS-BEAM DOUBLE

Art.-Nr./No. **40045** | EAN **4001690400459** | VPE/PU **2**

- ▶ 15 Luftkammern | Tubes
- ▶ Größe aufgeblasen | Size inflated ca. 210 x 140 x 20 cm
- ▶ Gewicht | Weight ca. 3,8 kg
- ▶ Belastbarkeit | Maximum load: 250 kg



## CROSS-BEAM KING

Art.-Nr./No. **40047** | EAN **4001690400473** | VPE/PU **2**

- ▶ 15 Luftkammern | Tubes
- ▶ Größe aufgeblasen | Size inflated ca. 210 x 185 x 20 cm
- ▶ Gewicht | Weight ca. 5,0 kg
- ▶ Belastbarkeit | Maximum load: 350 kg





# COMFORT PLUS LUFTBETTEN | AIR BEDS

## ANTI-RUTSCH-FUNKTION

durch spezielle Pads  
auf der Unterseite

## ANTI-SKID-FUNCTION

due to special pads  
on backside

### Komfort Luftbetten | Comfort air beds

- ▶ Grau-blau-schwarz | Grey-blue-black
- ▶ Luftbetten, ideal für Camping und als Gästebett |  
Air beds for outdoor and indoor use
- ▶ Pflegeleicht und schmutzabweisend | Easy to clean and dirt repellent
- ▶ Mit integrierter Fußpumpe minutenschnell aufgeblasen |  
Inflated within minutes with built in pump
- ▶ Mit Schnellentlüftungsventil | Fast venting valve for easier deflation
- ▶ Auch mit externer Hand- oder Fußpumpe aufblasbar |  
Optional to inflate with hand or foot pump
- ▶ Oberfläche aus organischer Viskose für herrlichen Schlafkomfort |  
Soft organic viscose top offering incomparable comfort
- ▶ Technischer Honeycomb Druck auf der Oberfläche | Technical honeycomb print on top
- ▶ Coil-Beam Konstruktion garantiert optimalen Komfort | Coil-Beam construction grant optimum comfort
- ▶ Anti-Rutsch-Funktion für glatten Untergrund | Anti-skid function on smooth surface

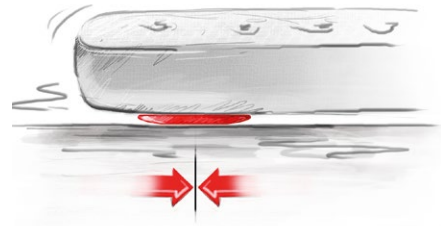

Video

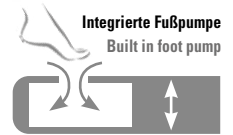

Integrierte Fußpumpe  
Built in foot pump

## COMFORT PLUS SINGLE

Art.-Nr./No. **40023** | EAN **4001690400237** |  
VPE/PU 3

- ▶ Größe aufgeblasen |  
Size inflated ca. 185 x 74 x 20 cm
- ▶ Gewicht | Weight ca. 1,9 kg
- ▶ Belastbarkeit | Maximum load: 100 kg



## COMFORT PLUS DOUBLE

Art.-Nr./No. **40025** | EAN **4001690400251** |  
VPE/PU 2

- ▶ Größe aufgeblasen |  
Size inflated ca. 197 x 138 x 20 cm
- ▶ Gewicht | Weight ca. 3,3 kg
- ▶ Belastbarkeit | Maximum load: 250 kg



## COMFORT PLUS KING

Art.-Nr./No. **40027** | EAN **4001690400275** |  
VPE/PU 2

- ▶ Größe aufgeblasen |  
Size inflated ca. 200 x 185 x 20 cm
- ▶ Gewicht | Weight ca. 4,5 kg
- ▶ Belastbarkeit | Maximum load: 350 kg



# LUFTBETTEN | AIR BEDS

## Luftbetten | Air beds

- ▶ Hellgrau-dunkelgrau | Light grey-dark grey
- ▶ Luftbetten, ideal für Camping und als Gästebett | Air beds for outdoor and indoor use
- ▶ Pflegeleicht und schmutzabweisend | Easy to clean and dirt repellent
- ▶ Mit Schnellentlüftungsventil | Fast venting valve for easier deflation
- ▶ Oberfläche aus organischer Viskose für herrlichen Schlafkomfort | Soft organic viscose top offering incomparable comfort
- ▶ Coil-Beam Konstruktion garantiert optimalen Komfort | Coil-Beam construction grant optimum comfort
- ▶ Anti-Rutsch-Funktion für glatten Untergrund | Anti-skid function on smooth surface

### ANTI-RUTSCH-FUNKTION

durch spezielle Pads auf der Unterseite

### ANTI-SKID-FUNCTION

due to special pads on backside

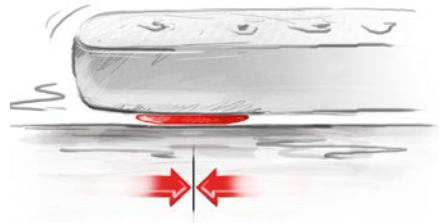

Video

## SINGLE

Art.-Nr./No. **40032** | EAN **4001690400329** | VPE/PU **4**

- ▶ Größe aufgeblasen | Size inflated ca. 185 x 74 x 20 cm
- ▶ Gewicht | Weight ca. 1,8 kg
- ▶ Belastbarkeit | Maximum load: 100 kg



## DOUBLE

Art.-Nr./No. **40034** | EAN **4001690400343** | VPE/PU **4**

- ▶ Größe aufgeblasen | Size inflated ca. 197 x 138 x 20 cm
- ▶ Gewicht | Weight ca. 3,2 kg
- ▶ Belastbarkeit | Maximum load: 250 kg



## KING

Art.-Nr./No. **40036** | EAN **4001690400367** | VPE/PU **2**

- ▶ Größe aufgeblasen | Size inflated ca. 200 x 185 x 20 cm
- ▶ Gewicht | Weight ca. 4,2 kg
- ▶ Belastbarkeit | Maximum load: 350 kg



# MULTI COMFORT PLUS

## Komfort Luftbett | Comfort air bed

- ▶ Grau-grün-schwarz | Grey-green-black
- ▶ Luftbett, ideal für Camping und als Gästebett | Air bed for outdoor and indoor use
- ▶ Pflegeleicht und schmutzabweisend | Easy to clean and dirt repellent
- ▶ Mit zwei integrierten Fußpumpen minutenschnell aufgeblasen | Inflated within minutes with the two built in pumps
- ▶ Mit Schnellentlüftungsventil | Fast venting valve for easier deflation
- ▶ Auch mit externer Hand- oder Fußpumpe aufblasbar | Optional to inflate with hand or foot pump
- ▶ Oberfläche aus organischer Viskose für herrlichen Schlafkomfort | Soft organic viscose top offering incomparable comfort
- ▶ Technischer Honeycomb Druck auf der Oberfläche | Technical honeycomb print on top
- ▶ Zwei separate Luftkammern für besten Schlafkomfort | Two separate air chambers for best sleep comfort
- ▶ Anti-Rutsch-Funktion für glatten Untergrund | Anti-skid function on smooth surface

### ANTI-RUTSCH-FUNKTION

durch spezielle Pads  
auf der Unterseite

### ANTI-SKID-FUNCTION

due to special pads  
on backside

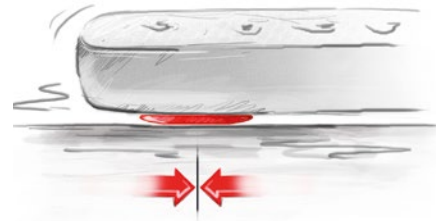

Video

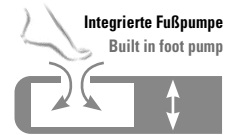

# MULTI COMFORT PLUS

Art.-Nr./No. **40053** | EAN **4001690400534** | VPE/PU 2

- ▶ Größe aufgeblasen | Size inflated ca. 198 x 137 x 22 cm,
- ▶ Gewicht | Weight ca. 3,9 kg
- ▶ Belastbarkeit | Maximum load: 250 kg

# SMOOTH COMFORT DOUBLE

## Luftbett mit integrierter Elektro-Pumpe | Air bed with built-in electric pump

- ▶ Hellgrau-dunkelgrau | Light grey-dark grey
- ▶ Luftbett, ideal für Camping und als Gästebett | Air bed for outdoor and indoor use
- ▶ Pflegeleicht und schmutzabweisend | Easy to clean and dirt repellent
- ▶ Einfaches und schnelles Aufblasen durch integrierte Elektropumpe | Easy and quick inflating with integrated electric pump
- ▶ Mit „Press & Safe“ Ventil | With “Press & Safe” valve
- ▶ Platzsparend zu verstauen | Easy to be stored
- ▶ Inklusive Tragetasche | Including carry bag



# SMOOTH COMFORT DOUBLE

Art.-Nr./No. **40051** | EAN **4001690400510** | VPE/PU 2

- ▶ Größe aufgeblasen | Size inflated ca. 204 x 136 x 40 cm
- ▶ Gewicht | Weight ca. 5,95 kg
- ▶ Belastbarkeit | Maximum load: 250 kg

## ELEKTROPUMPE 230 V



Art.-Nr./No. **49715** | EAN **4001690497152** |  
VPE/PU **3/12**

### Elektropumpe 230 V | Electric pump 230 V

- ▶ TÜV/GS geprüft | Certified
- ▶ Mit Netzteil für 230 V Anschluss | 230 V power supply
- ▶ 1,5 m Kabellänge | Cord length
- ▶ Zum Aufblasen und Entlüften von Aufblasartikeln | For inflating and deflating inflatables
- ▶ Mit 3 zusätzlichen Adaptern | Equipped with 3 adaptors
- ▶ Ca. 140 Watt | Appr. 140 Watt
- ▶ Max Luftdruck | Max. pressure 1,09 psi
- ▶ Luftvolumen | Air volume: 0,56 m<sup>3</sup>/min



## AKKU- / ELEKTROPUMPE 12/230 V



Art.-Nr./No. **49718** | EAN **4001690497183** |  
VPE/PU **3/12**

### Akku- / Elektropumpe 12 / 230 V | Accu- / electric pump 12 / 230 V

- ▶ TÜV/GS geprüft | Certified
- ▶ Mit 230 und 12 V-Anschluss zum Laden des Akkus | 230 V adaptor and 12 V-charging cable
- ▶ Zum Aufblasen und Entlüften von Aufblasartikeln | For inflating and deflating inflatables
- ▶ Mit 3 zusätzlichen Adaptern | Equipped with 3 adaptors
- ▶ Ca. 57 Watt | Appr. 57 Watt
- ▶ Max Luftdruck | Max. pressure 0,39 psi
- ▶ Luftvolumen | Air volume: 0,52 m<sup>3</sup>/min



## DOPPELHUBPUMPE



Art.-Nr./No. **49702** |  
EAN **4001690497022** |  
VPE/PU **3/6**

### Doppelhubpumpe | Double action pump

- ▶ TÜV/GS geprüft nach | Certified EN 16051-2 : 2002
- ▶ Fortdauernder Luftstrom bei Zug- und Druckbewegung | Dual action: continuous stream on both up and down stroke
- ▶ Extra Griff | Additional handle
- ▶ Zum Aufblasen und Entlüften von Aufblasartikeln | For inflating and deflating inflatables
- ▶ Mit Bajonett-Verschlässen, 4 Adaptern und langem, nicht knickendem Schlauch | Comes with large, non-kink hose and 4 sizes of interchangeable connecting nozzles
- ▶ Volumen: ca. 2 x 2.000 ccm | Volume: appr. 2 x 2.000 ccm
- ▶ Nenndruck bis 0,3 bar | Nominal pressure up to 0.3 bar



## BLASEBALG

Art.-Nr./No. **49721** |  
EAN **4001690497213** |  
VPE/PU **3/12**

### Blasebalg | Bellow pump

- ▶ Zum Aufblasen und Entlüften von Aufblasartikeln | For inflating and deflating inflatables
- ▶ Mit 3 Adaptern und langem, nicht knickendem Schlauch | Comes with large, non-kink hose and 3 sizes of interchangeable connecting nozzles
- ▶ Luftvolumen: ca. 5.000 ccm nach DIN 1.700 ccm | Air volume: appr. 5.000 ccm acc. to DIN 1.700 ccm



## SAVANNE POPUP MOSKITONETZ

Art.-Nr./No. **41510** |  
 EAN **4001690415101** |  
 VPE/PU **4/8**

### Pop up Moskitonetz | Pop up mosquito net

- ▶ Weiß | White
- ▶ 100 % Polyester
- ▶ 200 x 220 cm
- ▶ 55 Maschen | Mesh / cm<sup>2</sup>
- ▶ 590 g
- ▶ Polyester Packsack | Polyester bag



## LEICHTGEWICHT-HÄNGEMATTE

Art.-Nr./No. **41224** |  
 EAN **4001690412247** |  
 VPE/PU **3/24**

### Leichtgewicht Hängematte | Lightweight hammock

- ▶ Blau | Blue
- ▶ 210T Nylon, atmungsaktiv | Breathable
- ▶ 220 x 140 cm
- ▶ 350 g
- ▶ 2 Karabiner | 2 snap links
- ▶ 2 Spannseile je 204 cm | 2 ropes each 204 cm
- ▶ Nylon Packsack | Nylon bag

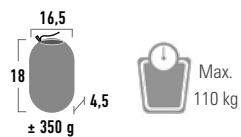

# SALOU

Art.-Nr./No. **44108** | EAN **4001690441087** | VPE/PU **6**

## Faltstuhl | Folding chair

- ▶ Dunkelgrau-blau | Dark grey-blue
- ▶ Bezug | Cover: 600D Polyester
- ▶ Rahmen | Frame: Stahl, Pulver beschichtet | Steel, powder coated 16 mm
- ▶ Abmessung | Size: 54 x 43,5 x 93 cm
- ▶ Sitzhöhe | Seating height: 41 cm
- ▶ Packmaß | Pack size: 90 x 14 x 10 cm
- ▶ Gewicht | Weight: 2,9 kg
- ▶ Belastbarkeit | Max. load: 100 kg
- ▶ Armlehne mit Getränkehalter | Armrest with cup holder
- ▶ Packsack 300 D Polyester | Stuff sac 300D polyester



## TARIFA

Art.-Nr./No. **44143** | EAN **4001690441438** | VPE/PU **24**

## Dreibein Hocker | 3-leg stool

- ▶ Dunkelgrau-blau | Dark grey-blue
- ▶ Bezug | Cover: 600D Polyester
- ▶ Rahmen | Frame: Stahl, Pulver beschichtet | Steel, powder coated 19 mm
- ▶ Abmessung | Size: 33 x 33 x 45 cm
- ▶ Packmaß | Pack size: 59 x 9,5 x 9,5 cm
- ▶ Gewicht | Weight: 0,65 kg
- ▶ Belastbarkeit | Max. load: 100 kg
- ▶ Schultergurt | Shoulder carry strap

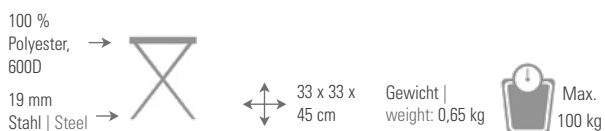

**Faltstuhl | Folding chair**

- ▶ Dunkelgrau-blau | Dark grey-blue
- ▶ Bezug | Cover: 600D Polyester
- ▶ Rahmen | Frame: Stahl, Pulver beschichtet | Steel, powder coated 19 mm
- ▶ Abmessung | Size: 62 x 60 x 105 cm
- ▶ Sitzhöhe | Seating height: 48 cm
- ▶ Packmaß | Pack size: 98 x 26 x 18 cm
- ▶ Gewicht | Weight: 4,6 kg
- ▶ Belastbarkeit | Max. load: 120 kg
- ▶ Gepolsterter Sitz und Rückenlehne | Padded seat and back rest
- ▶ 3-fach verstellbare Rückenlehne | 3-position adjustable back rest
- ▶ Verstellbare Armlehnen | Adjustable armrest
- ▶ Isolations-Getränkhalter | Insulated cup holder
- ▶ Abnehmbares Kopfkissen | Removable pillow
- ▶ Packsack 300 D Polyester | Stuff sac 300D polyester



**OVIEDO**Art.-Nr./No. **44160** | EAN **4001690441605** | VPE/PU 1**Camping Faltbett | Camping folding bed**

▶ Dunkelgrau-blau | Dark grey-blue

- ▶ Bezug | Cover: 600D Polyester
- ▶ Rahmen | Frame: Stahl, Pulver beschichtet | Steel, powder coated 22 mm
- ▶ Abmessung | Size: 190 x 65 x 45 cm

- ▶ Packmaß | Pack size: 95,5 x 14,5 x 12,5 cm
- ▶ Gewicht | Weight: 7,9 kg
- ▶ Belastbarkeit | Max. load: 120 kg

▶ Packsack 300 D Polyester | Stuff sac 300D polyester

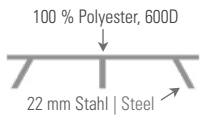

↕ 190 x 65 x 45 cm

7,9 kg

Max. 120 kg

**TOLEDO XL**Art.-Nr./No. **44165** | EAN **4001690441650** | VPE/PU 1**Camping Faltbett | Camping folding bed**

▶ Dunkelgrau-blau | Dark grey-blue

- ▶ Bezug | Cover: 600D Polyester
- ▶ Rahmen | Frame: Aluminium | Alloy 25 x 25 mm
- ▶ Abmessung | Size: 205 x 78 x 51 cm

- ▶ Packmaß | Pack size: 102,5 x 15,5 x 15,5 cm
- ▶ Gewicht | Weight: 8,1 kg
- ▶ Belastbarkeit | Max. load: 120 kg

▶ Packsack 300 D Polyester | Stuff sac 300D polyester

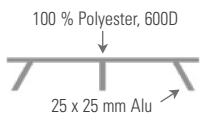

↕ 205 x 78 x 51 cm

8,1 kg

Max. 120 kg



## Camping Tisch | Camping table

- ▶ Gestell | Frame: Aluminium | Alloy 19 mm
- ▶ Tischplatte | Tabletop: Aluminium | Alloy
- ▶ Abmessung | Size: 70 x 70 x 70 cm
- ▶ Packmaß | Pack size: 102,5 x 15,5 x 15,5 cm
- ▶ Gewicht | Weight: 2,9 kg

- ▶ Höhenverstellbare FüÙe | Adjustable legs
- ▶ Rollbare Tischplatte | Roll up table top
- ▶ Packsack 300 D Polyester | Stuff sac 300D polyester

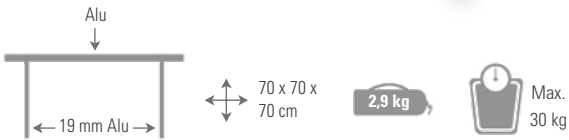

## Camping Tisch | Camping table

- ▶ Gestell | Frame: Aluminium | Alloy 25 x 25 mm
- ▶ Tischplatte | Tabletop: Aluminium | Alloy
- ▶ Abmessung | Size: 110 x 72 x 70 cm
- ▶ Packmaß | Pack size: 159 x 20,5 x 12,5 cm
- ▶ Gewicht | Weight: 6,3 kg

- ▶ Höhenverstellbare FüÙe | Adjustable legs
- ▶ Rollbare Tischplatte | Roll up table top
- ▶ Packsack 300 D Polyester | Stuff sac 300D polyester





## KOMPRESSIONSPACKSACK

### Kompressionspacksack | Compression bag

- ▶ Schwarz | Black
- ▶ 210D Oxford Polyester
- ▶ 4 Kompressionsgurte | 4 compression straps
- ▶ Quick Lock Kordel-Verschluss | Quick lock draw cord closure
- ▶ Öffnung mit Abdeckklappe gegen Schmutz | Mouth opening with anti dust flap



### KOMPRESSIONSPACKSACK M

Art.-Nr./No. **23540** |  
 EAN **4001690235402** |  
 VPE/PU **5/50**



### KOMPRESSIONSPACKSACK L

Art.-Nr./No. **23545** |  
 EAN **4001690235457** |  
 VPE/PU **5/50**





## DRY BAGS

- ▶ Schwarz | Black
- ▶ 190T Nylon PVC beschichtet nahtversiegelt | Coated taped
- ▶ Rollverschluss | Roll down closure
- ▶ Duraflex Verschlüsse | Duraflex closure

### DRY BAG XXXS

Art.-Nr./No. **32055** | EAN **4001690320559** | VPE/PU **5/50**

- ▶ Volumen | Volume: 1 l
- ▶ 45 g
- ▶ 24 x ø 11 cm

### DRY BAG XXS

Art.-Nr./No. **32057** | EAN **4001690320573** | VPE/PU **5/50**

- ▶ Volumen | Volume: 2 l
- ▶ 50 g
- ▶ 29 x ø 13 cm

### DRY BAG XS

Art.-Nr./No. **32059** | EAN **4001690320597** | VPE/PU **5/50**

- ▶ Volumen | Volume: 4 l
- ▶ 60 g
- ▶ 33 x ø 15 cm

### DRY BAG S

Art.-Nr./No. **32061** | EAN **4001690320610** | VPE/PU **5/50**

- ▶ Volumen | Volume: 7 l
- ▶ 100 g
- ▶ 40 x ø 18 cm



### DRY BAG M

Art.-Nr./No. **32063** | EAN **4001690320634** | VPE/PU **5/50**

- ▶ Volumen | Volume: 15 l
- ▶ 140 g
- ▶ 54 x ø 22 cm

### DRY BAG L

Art.-Nr./No. **32065** | EAN **4001690320658** | VPE/PU **5/50**

- ▶ Volumen | Volume: 26 l
- ▶ 175 g
- ▶ 68 x ø 26 cm

**PALERMO**Art.-Nr./No. **32071** | EAN **4001690320719** | VPE/PU **10/100****Brustbeutel |  
Neck wallet**

▶ Schwarz | Black

- ▶ 100 % 70D Nylon Rip Stop PU
- ▶ Rückseite hautfreundliches Mesh |  
Skin friendly mesh back
- ▶ 15 x 11,5 cm
- ▶ 25 g
- ▶ 2 Taschen verschließbar mittels Klettverschluss |  
2 pockets with velcro closure
- ▶ Umhängeband mit Kordelzug |  
Neck lace with cord lock

**TORINO**Art.-Nr./No. **32073** | EAN **4001690320733** | VPE/PU **10/100****Hüfttasche |  
Waist pouch**

▶ Schwarz | Black

- ▶ 100 % 70D Nylon Rip Stop PU
- ▶ Rückseite hautfreundliches Mesh |  
Skin friendly mesh back
- ▶ 25 x 13 cm
- ▶ 40 g
- ▶ 1 RV Tasche | 1 zipped pocket
- ▶ Elastischer Hüftgurt | Elastic waist belt

**MESSINA**Art.-Nr./No. **32072** | EAN **4001690320726** | VPE/PU **10/100****Brustbeutel |  
Neck wallet**

▶ Schwarz | Black

- ▶ 100 % 70D Nylon Rip Stop PU
- ▶ Rückseite hautfreundliches Mesh |  
skin friendly mesh back
- ▶ 24 x 14 cm
- ▶ 50 g
- ▶ 2 RV Taschen, 5 Einschubfächer |  
2 zipped pockets, 5 sleeve pockets
- ▶ Umhängeband mit Kordelzug |  
Neck lace with cord lock



# NAPOLI

Art.-Nr./No. 32074 | EAN 4001690320740 | VPE/PU 10/100

## Hüfttasche | Waist pouch

▶ Schwarz | Black

- ▶ 100 % 70D Nylon Rip Stop PU
- ▶ Rückseite hautfreundliches Mesh | Skin friendly mesh back
- ▶ 32,5 x 14 cm
- ▶ 65 g
- ▶ 2 RV Taschen mit Organizer | 2 zipped pockets with organizer
- ▶ Elastischer Hüftgurt | Elastic waist belt



# TIGRA

Art.-Nr./No. 32075 | EAN 4001690320757 | VPE/PU 5/50

## Hüfttasche | Waist pouch

▶ Schwarz | Black

- ▶ 100 % Nylon 420D Rip Stop PU, 100 % Polyester 600D PU
- ▶ Gepolsteter Rücken mit 3 D Mesh | Padded back with 3 D mesh
- ▶ 30 x 18 x 6 cm
- ▶ 120 g
- ▶ 2 RV Taschen | 2 zipped pockets
- ▶ Hüftgurt | Waist belt



# VISTA

Art.-Nr./No. 32076 | EAN 4001690320764 | VPE/PU 5/50

## Faltbarer Kulturbeutel | Foldable toiletry bag

▶ Schwarz | Black

- ▶ 100 % Polyester 600D PU
- ▶ 49,5 x 25,5 cm
- ▶ 110 g
- ▶ 3 RV Taschen | 3 zipped pockets,
- ▶ 4 Einschubtaschen | 4 sleeve pockets
- ▶ Hängevorrichtung | Hanging hook



**THERMOBECHER**

Art.-Nr./No. **41472** |  
 EAN **4001690414722** |  
 VPE/PU **12**

**Doppelwand Thermobecher |  
Double thermo mug**

- ▶ Schwarz | Black
  - ▶ Edelstahl | Stainless steel
  - ▶ Volumen | Volume: 0,42 l
  - ▶ 190 g
- ▶ Deckel mit Trinkverschluss |  
Lid and closeable spout

**THERMOFLASCHE 0,5 L**

Art.-Nr./No. **41470** |  
 EAN **4001690414708** |  
 VPE/PU **12**

**Doppelwand Thermoflasche |  
Double thermo flask**

- ▶ Schwarz | Black
  - ▶ Edelstahl | Stainless steel
  - ▶ Volumen | Volume: 0,5 l
  - ▶ 335 g
- ▶ Hygienischer Dreh-  
und Gießverschluss |  
Hygienic screw and pour neck
  - ▶ Heiß- und Kaltgetränke |  
Hot and cold beverages

**THERMOFLASCHE 1,0 L**

Art.-Nr./No. **41471** |  
 EAN **4001690414715** |  
 VPE/PU **12**

**Doppelwand Thermoflasche |  
Double thermo flask**

- ▶ Schwarz | Black
  - ▶ Edelstahl | Stainless steel
  - ▶ Volumen | Volume: 1,0 l
  - ▶ 515 g
- ▶ Hygienischer Dreh-  
und Gießverschluss |  
Hygienic screw and pour neck
  - ▶ Heiß- und Kaltgetränke |  
Hot and cold beverages



## TRINKBECHER 0,3 L

Art.-Nr./No. **41473** |  
EAN **4001690414739** |  
VPE/PU **12**

### Doppelwand Trinkbecher | Double wall mug

- ▶ Silber | Silver
- ▶ Edelstahl | Stainless steel
- ▶ Volumen | Volume: 0,3 l
- ▶ 115 g



## TRINKFLASCHE 0,6 L

Art.-Nr./No. **41476** |  
EAN **4001690414760** |  
VPE/PU **12**

### Trinkflasche | Drinking bottle

- ▶ Schwarz | Black
- ▶ Aluminium | Aluminium
- ▶ Volumen | Volume: 0,6 l
- ▶ 90 g
- ▶ Schraubverschluss |  
Screw cap
- ▶ Befestigungskarabiner |  
Snap link

## TRINKFLASCHE 1,0 L

Art.-Nr./No. **41477** |  
EAN **4001690414777** |  
VPE/PU **12**

### Trinkflasche | Drinking bottle

- ▶ Schwarz | Black
- ▶ Aluminium | Aluminium
- ▶ Volumen | Volume: 1,0 l
- ▶ 135 g
- ▶ Schraubverschluss |  
Screw cap
- ▶ Befestigungskarabiner |  
Snap link



**STAHL ERDNAGEL** Art.-Nr./No. **42207** | EAN **4001690422079** | VPE/PU **10/50****Stahl Erdnagel |  
Steel pin peg**

- ▶ Stahl silber verzinkt | Steel silver galvanized
- ▶ 180 x 5 mm / 32 g / (10 Stk. | Pcs)
- ▶ Für Mischböden |  
For most ground conditions

**STAHL HERING** Art.-Nr./No. **42205** | EAN **4001690422055** | VPE/PU **10/50****Stahl Hering |  
Steel V peg**

- ▶ Stahl silber verzinkt | Steel silver galvanized
- ▶ 180 x 22 mm / 39 g / (6 Stk.. | Pcs)
- ▶ Für Mischböden |  
For most ground conditions

**STAHL HERING MIT HAKEN** Art.-Nr./No. **42209** | EAN **4001690422093** | VPE/PU **10/50****Stahl Hering mit Haken |  
Steel V peg with hook**

- ▶ Stahl silber verzinkt | Steel silver galvanized
- ▶ 240 x 20 mm / 60 g / (6 Stk.. | Pcs)
- ▶ Zughaken | Pull hook
- ▶ Für Mischböden |  
For most ground conditions

**STAHL T-HERING** Art.-Nr./No. **42211** | EAN **4001690422116** | VPE/PU **10/50****Stahl T-Hering |  
Steel T shaped peg**

- ▶ T-Stahlprofil silber verzinkt |  
T-steel profile silver galvanized
- ▶ 300 x 20 mm / 190 g / (2 Stk.. | Pcs)
- ▶ Sturm-Abspannung und für harte Böden |  
Storm and extreme conditions

**STAHL RINGKOPF ERDNAGEL** Art.-Nr./No. **42213** | EAN **4001690422130** | VPE/PU **10/50****Stahl Ringkopf Erdnagel |  
Steel round peg**

- ▶ Stahl silber verzinkt | Steel silver galvanized
- ▶ 200 x 4 mm / 26 g / (6 Stk.. | Pcs)
- ▶ Spezial Zeltnagel für Zeltplanen |  
Special peg with flattened head for ground sheets
- ▶ Für Mischböden | For most ground conditions

**ALUMINIUM ERDNAGEL** Art.-Nr./No. **42227** | EAN **4001690422277** | VPE/PU **10/50****Aluminium Erdnagel |  
Aluminium pin peg**

- ▶ Aluminium
- ▶ 180 x 6 mm / 16 g / (6 Stk.. | Pcs)
- ▶ Für Mischböden |  
For most ground conditions





**ALUMINIUM HERING** Art.-Nr./No. **42225** | EAN **4001690422253** | VPE/PU **10/50****Aluminium Hering |  
Aluminium V peg**

- ▶ Aluminium
- ▶ 185 x 18 mm / 16 g / (6 Stk. | Pcs)
- ▶ Für Mischböden |  
For most ground conditions

**ABS ZELTBODEN RUNDKOPF-HERING** Art.-Nr./No. **42216** | EAN **4001690422161** | VPE/PU **10/50****ABS Rundkopfhering |  
ABS mushroom peg**

- ▶ Copolymer
- ▶ 130 mm / 6 g / (6 Stk. | Pcs)
- ▶ Für weiche Böden, Zeltteppiche und Planen | For  
Softer ground conditions, tent carpets and ground sheets
- ▶ Breiter flacher Kopf | Flat top

**ABS HERING** Art.-Nr./No. **42200** | EAN **4001690422000** | VPE/PU **10/50****ABS Hering |  
ABS peg**

- ▶ Copolymer
- ▶ 200 mm / 22 g / (6 Stk. | Pcs)
- ▶ Für Mischböden |  
For most ground conditions

**ABS GLÜHWURM HERING** Art.-Nr./No. **42202** | EAN **4001690422024** | VPE/PU **10/50****Glow in the dark  
ABS Hering |  
Glow in the dark  
ABS peg**

- ▶ Phosphoreszierend Copolymer |  
Phosphorescent copolymer
- ▶ 200 mm / 22 g / (6 Stk.)
- ▶ Für Mischböden |  
For most ground conditions

**HERINGSZIEHER** Art.-Nr./No. **41415** | EAN **4001690414159** | VPE/PU **3/48****Heringszieher |  
Peg extractor**

- ▶ Stahl verzinkt  
mit Kunststoffgriff |  
Galvanized steel  
with plastic handle



**GUMMI HAMMER** Art.-Nr./No. **41411** | EAN **4001690414111** | VPE/PU **5/50****Gummi Hammer |  
Rubber mallet**

- ▶ Gummi Schlagkopf | Rubber hammer head
- ▶ 27 x 8 x 5 cm
- ▶ 230 g
- ▶ Holzstiel mit Heringszieher |  
Wooden handle with peg extractor

**KLAPPSPATEN** Art.-Nr./No. **41422** | EAN **4001690414227** | VPE/PU **2/14****Klappspaten |  
folding shovel**

- ▶ Stahl | Steel
- ▶ 60 x 15 x 6 cm
- ▶ 995 g
- ▶ Packmaß |  
Packed size:  
25 x 16,5 x 6 cm

**STURMLEINEN MIT STOPPER** Art.-Nr./No. **42258** | EAN **4001690422581** | VPE/PU **10/100****SturMLEinen Set |  
Guyrope set**

- ▶ 2-Farb Polypropylen | Bi color Polypropylene
- ▶ 350 cm x 3 mm / (6 Stk. | Pcs)
- ▶ 3 Loch Stopper Kunststoff |  
3 hole runner plastic

**DREILOCHSPANNER** Art.-Nr./No. **42260** | EAN **4001690422604** | VPE/PU **10/100****Dreilochspanner |  
Triangular runner**

- ▶ 40 x 22 mm / (6 Stk.. | Pcs)

**ABSPANN-GUMMIS**Art.-Nr./No. **42250** | EAN **4001690422505** | VPE/PU **10/100**

- ▶ 110 x 7 x 2 mm / (6 Stk.. | Pcs)

**Abspann-Gummis |  
Peg rubber rings**Art.-Nr./No. **42252** | EAN **4001690422529** | VPE/PU **10/100**

- ▶ 160 x 7 x 2 mm / (6 Stk.. | Pcs)



## FIBERGLASS-REPARATURSET

### Fiberglass-Reparaturset | Fiber glass repair kit

- ▶ Fiberglass, 4 teilig | 4 pcs.
- ▶ Elastikband |  
Short cord 400 cm



### FIBERGLASS-REPARATURSET

Art.-Nr./No. **41710** | EAN **4001690417105** | VPE/PU **5/50**

- ▶ 7,9 mm, 200 cm

### FIBERGLASS-REPARATURSET

Art.-Nr./No. **41711** | EAN **4001690417112** | VPE/PU **5/50**

- ▶ 8,5 mm, 200 cm

### FIBERGLASS-REPARATURSET

Art.-Nr./No. **41712** | EAN **4001690417129** | VPE/PU **5/50**

- ▶ 9,5 mm, 200 cm

### FIBERGLASS-REPARATURSET

Art.-Nr./No. **41713** | EAN **4001690417136** | VPE/PU **5/30**

- ▶ 11,0 mm, 200 cm

## TELESKOP-ZELTSTANGE Art.-Nr./No. 42285 | EAN 4001690422857 | VPE/PU 3/15

### Teleskop Zeltstange | Telescopic tent pole

- ▶ Stahl verzinkt | Steel galvanized
- ▶ 170 - 255 cm, 22 mm dia



## ZELT ROLLPACKTASCHE

### Zelt Rollpacktasche | Tent roll down bag

- ▶ 150D Oxford Polyester PU
- ▶ Kompressionsgurte | Compressure straps
- ▶ Tragegriff | Carry handle



### ZELT ROLLPACKTASCHE

Art.-Nr./No. **41785** |  
EAN **4001690417853** |  
VPE/PU **5/40**

- ▶ 3-4 Pers., 80 x 30 cm

### ZELT ROLLPACKTASCHE

Art.-Nr./No. **41786** |  
EAN **4001690417860** |  
VPE/PU **5/40**

- ▶ 4-5 Pers., 85 x 35 cm

### ZELT ROLLPACKTASCHE

Art.-Nr./No. **41787** |  
EAN **4001690417877** |  
VPE/PU **5/40**

- ▶ 5-6 Pers., 102 x 37 cm

**NAHTDICHTER**

Art.-Nr./No. **41702** | EAN **4001690417020** |  
VPE/PU **6/48**

- ▶ Für technische Gewebearten |  
For technical fabrics
- ▶ 100 ml

**IMPRÄGNIERSPRAY**

Art.-Nr./No. **41705** | EAN **4001690417051** |  
VPE/PU **6/12**

- ▶ Auf Wasserbasis
- ▶ Für technische u. Natur Gewebearten |  
For technical and organic fabrics
- ▶ 400 ml

**PE ABDECKPLANE PE cover**

Art.-Nr./No. **41730** | EAN **4001690417303** | VPE/PU **3/24**

- ▶ 230 x 160 cm, 6 Ösen | Eyelets

Art.-Nr./No. **41731** | EAN **4001690417310** | VPE/PU **3/12**

- ▶ 250 x 230 cm, 8 Ösen | Eyelets

Art.-Nr./No. **41732** | EAN **4001690417327** | VPE/PU **3/12**

- ▶ 300 x 250 cm, 10 Ösen | Eyelets

**ALUKISSEN Alu pads**

Art.-Nr./No. **41325** | EAN **4001690413251** | VPE/PU **3/60**

- ▶ Silber | Silver
- ▶ Alu Folie | Foil + PE Schaum | Foam 105 g/m<sup>2</sup>
- ▶ 35 x 45 x 0,2 cm
- ▶ 45 g
- ▶ 2 Stk in Schrumpffolie und Einleger | 2 pcs in shrink packing and insert sheet

**ALUMATTE SINGLE Alu mat single**

Art.-Nr./No. **41090** |  
EAN **4001690410908** | VPE/PU **3/24**

- ▶ Silber | Silver
- ▶ 190 x 60 x 0,2 cm / 130 g

- ▶ Alu Folie | Foil + PE Schaum |  
Foam 105 g/m<sup>2</sup>
- ▶ 2 Gurte mit Tragegriff |  
2 straps with handle

**ALUMATTE DUO Alu mat duo**

Art.-Nr./No. **41095** |  
EAN **4001690410953** | VPE/PU **2/12**

- ▶ Silber | Silver
- ▶ 190 x 120 x 0,2 cm / 240 g



## FALTBARER WASSERTANK Foldable jerry can

Art.-Nr./No. **41460** | EAN **4001690414609** |  
VPE/PU **12**

- ▶ 100 % Polyethylen |  
100 % polyethylene
- ▶ Drehverschluss |  
Rotary closure
- ▶ 15 l



## SOLAR DUSCHE Solar shower

Art.-Nr./No. **41450** | EAN **4001690414500** |  
VPE/PU **2/24**

- ▶ 100 % PVC ungiftig |  
100 % PVC non toxic
- ▶ Brausekopf |  
Shower head
- ▶ Hängevorrichtung |  
Hang up system
- ▶ 20 l



## WASSERKANISTER MIT BÜGELGRIFF Jerry can with handle

Art.-Nr./No. **41463** | EAN **4001690414630** |  
VPE/PU **20**

- ▶ Polyethylen | Polyethylene
- ▶ Extra große Öffnung DIN 96 (80 mm)  
für leichte Innenreinigung per Hand |  
Extra wide opening DIN 96 (80 mm)  
for easy cleaning inside by hand
- ▶ Lebensmittelecht | Food-safe
- ▶ Mit regulierbarem Wasserhahn |  
With adjustable tap
- ▶ Inkl. Bügelgriff | Incl. handle
- ▶ 10 l
- ▶ 28 x 28 x 17 cm (h x b x t)



## WASSERKANISTER Jerry can

Art.-Nr./No. **41464** | EAN **4001690414647** |  
VPE/PU **10**

- ▶ Polyethylen | Polyethylene
- ▶ Extra große Öffnung DIN 96 (80 mm)  
für leichte Innenreinigung per Hand |  
Extra wide opening DIN 96 (80 mm)  
for easy cleaning inside by hand
- ▶ Lebensmittelecht | Food-safe
- ▶ Mit regulierbarem Wasserhahn |  
With adjustable tap
- ▶ 19 l
- ▶ 47 x 28 x 17 cm (h x b x t)





## OUR SERVICES



### Unsere Services.

Unsere Service-Hotlines können Sie montags bis donnerstags von 07:30 bis 16:30 Uhr und freitags von 07:30 bis 13:00 Uhr erreichen.

Vertrieb Inland	+49 2162 10200 0
Vertrieb Ausland	+49 2162 10200 0
Ersatzteillieferungen	+49 2162 10200 25

Detaillierte Artikelbeschreibungen, Fließtexte, Produktfotos und Detailaufnahmen für alle Produkte sowie Produktvideos zu Zelten und Schlafsäcken stellen wir Ihnen auf Anfrage zur Verfügung.

### Our services.

Our service-hot lines are available from Monday through Thursday 07:30 till 16:30 and on Friday 07:30 till 13:00.

National sales	+49 2162 10200 0
International sales	+49 2162 10200 0
Spare parts supply	+49 2162 10200 25

Detailed product descriptions, running texts, product photos and detailed images for all products as well as product videos for tents and sleeping bags will be provided on request.

For other countries please contact us via email: [info@simexoutdoor.com](mailto:info@simexoutdoor.com)



# Beste Aussichten für Ihr Business.

## Best prospects for your business.



Unser Außendienst betreut Sie und schult Ihr Personal auf Wunsch vor Ort.

Our sales team takes care of you and provides your staff with on-demand training.

- ▶ Bayern, Baden-Württemberg, Nordrhein-Westfalen  
Nina Brauch  
+49 160 32 96 979
- ▶ Sachsen, Sachsen-Anhalt, Thüringen, Berlin, Brandenburg, Schleswig-Holstein, Hamburg, Niedersachsen, Mecklenburg-Vorpommern, Bremen  
Thomas Krüger  
+49 174 3 14 49 86

**Messeteilnahmen.**  
Fair participation.

Wir veranstalten jährlich im Zeitraum Mai-August unsere Hausmesse, auf der wir die Neuheiten für die kommende Saison präsentieren. Des Weiteren vereinbaren wir mit Ihnen gerne einen persönlichen Termin in unserem Showroom in Viersen.

Every year in the period Mai - August we hold our in-house exhibition, where we present our new products for the coming season to our partners. We are also happy to arrange a personal appointment with you at our showroom in Viersen.



